

# **STATIONARY LOW-POWER PLANT NUMBER 1, SL-1 ACCIDENT**

©M. Ragheb  
11/10/2020

## **INTRODUCTION**

The SL-1 reactor, originally named Argonne Low Power Reactor, ALPR, was designed for the USA Army as a prototype of a low-power, 300 kWe boiling-water reactor plant to be used in geographically remote locations. Due to the need for small size, highly enriched uranium to the level of 93 percent was used, similarly to the design of naval propulsion reactors.

The SL-1 was accidentally destroyed in a prompt criticality accident caused by the accidental ejection of a control rod during maintenance operations, followed by a steam explosion causing the death of 3 persons on January 3, 1961.

## **UNDERLYING PROJECT**

The USA Army was developing the Distant Early Warning, DEW system. By 1953, dozens of manned radar stations ringed the Arctic Circle, on watch against a possible air attack. The Army regularly shipped diesel fuel to these stations for heat and electricity. This was costly and hazardous in such remote areas, and the use of nuclear reactors would have solved the problem. The Army reactors were designated as “stationary,” “portable,” or “mobile,” depending on the intended field application, and rated as “low,” “medium,” or “high” power.

The goal was for a 3-4 parts power plant that can fit into cargo planes or trucks, and that could be assembled in a few hours in the case of a sudden conflict. The plant would run at least three years on one fuel loading, hence highly enriched uranium was needed. It needs to generate only about 1 MWth. At the end of a mission, crews would unpack it and ship it to some other location.

The project involved using a boiling water reactor concept eliminating the weight and complexity of a steam generator and a secondary loop. It was also hoped that ordinary air could be used as a gaseous coolant in the Gas Cooled Reactor Experiment, later replaced by N<sub>2</sub> in the Mobile Low-Power Reactor, ML-1 further simplifying the power plant and eliminating weight. The USA Army successfully operated its prototype Stationary Medium-Power, SM-1 reactor at Fort Belvoir, Virginia, at a distance of 18 miles from the White House.

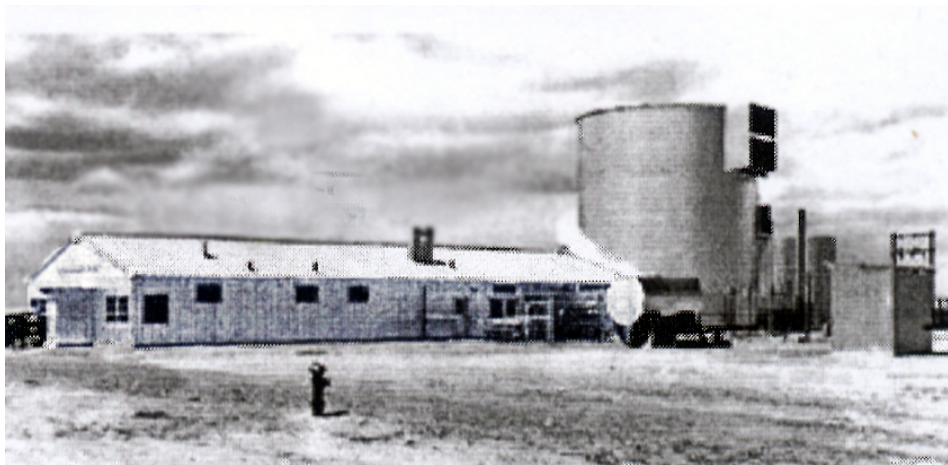

Figure 1. SL1 Boiling Water Reactor view.

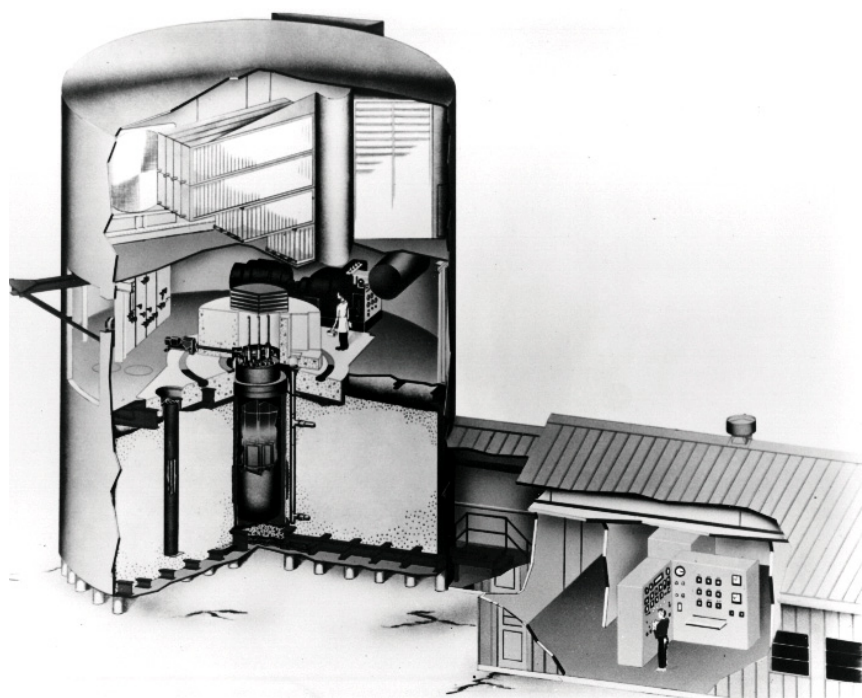

Figure 2. Cutout in SL-1 reactor building.

### **PRELUDE TO ACCIDENT**

On December 23, 1960 the reactor was shut down for Christmas. The maintenance crews returned back on December 27, 1960 operating in three shifts around the clock. The reactor was scheduled to start up on January 4, 1961.

The crews calibrated instruments and maintained to the valves, pipes, and pump that circulated coolant water through the reactor. To do this work, the water level in the reactor was lowered about two feet. A task was to insert 44 Co flux wires into the reactor core for mapping of the reactor's neutron flux.

On January 3, 1961, the day shift inserted the flux wires. To gain access to the reactor core, they had to move out of the way several large concrete shielding blocks that ringed the top of the reactor. They disconnected the control rods from their drive mechanisms which were also in the way in the way. It was the task of the 4 pm shift to reconnect the control rods to the drive mechanism.

The weather in the desert of Idaho was cold with the temperature expected to reach for 17 degrees below zero that night.

The three person crew arrived at the reactor site from the city of Idaho Falls and set to work. They were the only workers at the SL-1 site. For night shifts, no guards were posted at the entry gate, which the day-shift had locked behind them as they left.

### ACCIDENT PROGRESSION

The reconnection of the drive mechanisms involved several steps, one of which was to manually lift the control rod about 3 inches out of the reactor. At the top of the control rod is a small ball. A “gripper” from the drive mechanism latched onto this ball, completing the connection between the rod and the rest of the mechanism and its motor drive.

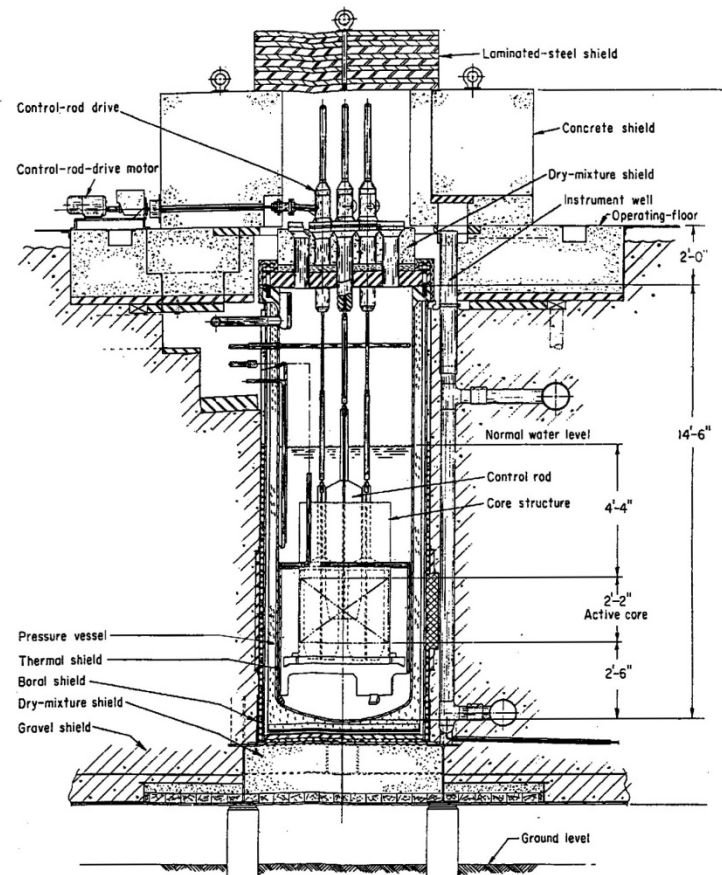

Figure 3. Schematic of SL1 reactor.

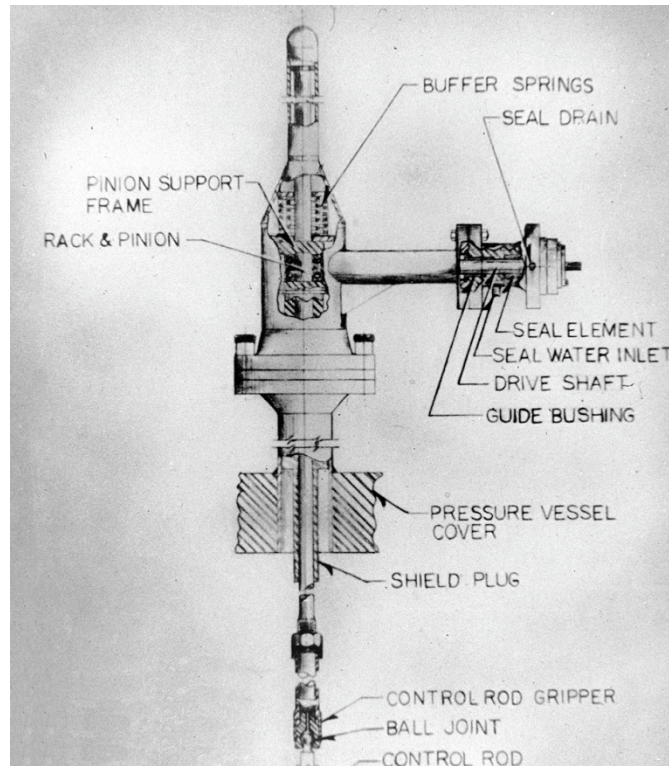

Figure 4. Cruciform control-rod drive mechanism of SL-1 reactor.

The control rods were cruciform in shape, with four narrow fin-like projections that moved up and down the length of the reactor core in narrow sheaths. The fuel zone was about 28 inches in height. Moving the rods three inches was safe and not enough to invite a chain reaction. Accidentally pulling the rod by yanking it the full 28 inches length of the core would introduce enough positive reactivity to send the reactor into a prompt (neutrons) criticality mode.

In the previous weeks, the control rods seemed to stick slightly, perhaps because other items in the reactor core had bowed, invading the clearance spaces and placing pressure on the sheath, crowding the slender fins of the control rods.

The three crew members entered the reactor silo at 9 pm, two of them directly over or very close to the top of the reactor, working with the central control rod.

At 9:01 pm something happened causing the reactor power to go “prompt critical” with power increasing exponentially.

### **STEAM EXPLOSION**

When the reactor went prompt critical, it released so much heat energy in 4 milliseconds that it flashed the water surrounding the fuel to steam. The steam, being of lower density than the liquid water and thus a less effective moderator, quenched the nuclear reaction.

The decay heat built up rapidly. With no system operating to remove the heat, 20 percent of the fuel melted. The steam forced upwards the 7-foot column of still-liquid water above it.

The water rushed as a piston or water hammer through the two feet of air space. It slammed against the lid of the pressure vessel at a speed of 160 ft/sec and 10,000 pounds per square inch (psi) pressure. The entire vessel jumped nine feet into the air, hit the ceiling, and fell back into place, shearing all of its connections to the piping and instrumentation systems.

Iron pellets packed near the reactor as thermal insulation and radiation shielding scattered over the floor. The water hammer expelled the control-rod shield plugs, water, fuel fragments, fission products, and other metal from the top of the reactor, leaving open holes.

The violence of the explosion caused the death of all the crew members. Two of them died instantly, one was thrown sideways against a shielding block and the other straight upwards, where one of the shield plugs pinned his body to the ceiling. The head wounds of the third crew member were fatal, but his pulse continued for another two hours.

The steam explosion blew shards of radioactive metal into their bodies, causing a dose rate of 500 rad/hr, making them a hazard to the rescue and recovery teams. The radiation dose rate in the reactor building reached 1,000 rad/hr; a fatal level. If the explosion would not have not killed the victims, the radiation levels attained would have done it.

The accident was unprecedented with the first reactor casualties in the history of the then 14 years old Atomic Energy Commission, AEC.



Figure 5. Top view of the damaged SL-1 core.

## **AFTERMATH**

A cloud of radioactive  $I^{131}$  drifted south, but its dispersion and mixing with air had reduced its concentration well below any health concerns. Ground surveys found that the only place needing to be quarantined was the immediate SL-1 yard, where the rescue attempt had tracked some contamination. Beyond there, amounts above background levels were negligible.

The core no longer contained any moderating water and that meant that the reactor could not go critical again. The SL-1 reactor should have been inherently safe and an investigation was conducted regarding what went wrong. Calculations indicated that the vessel may have risen enough to hit the ceiling immediately following the brief nuclear excursion, severing the piping connections.

Examinations revealed scratch marks confirming that the central control rod had been manually withdrawn 26 ¼ inches. This was an unsafe position compared with the 3 inches safe withdrawal position, sending the reactor into prompt criticality.

## **MOBILE LOW POWER REACTOR 1, ML-1, USA ARMY CAMP CENTURY-1**

The ML-1 reactor was the first closed cycle gas turbine reactor. It was cooled by pressurized  $N_2$  gas. It was designed for 300 kW but only achieved a power level of 140 kW.



Figure 6. USA Army's Camp Century-1, Greenland, Denmark Portable Nuclear Power plant PM-2A, pressure vessel. Source: USA Army.

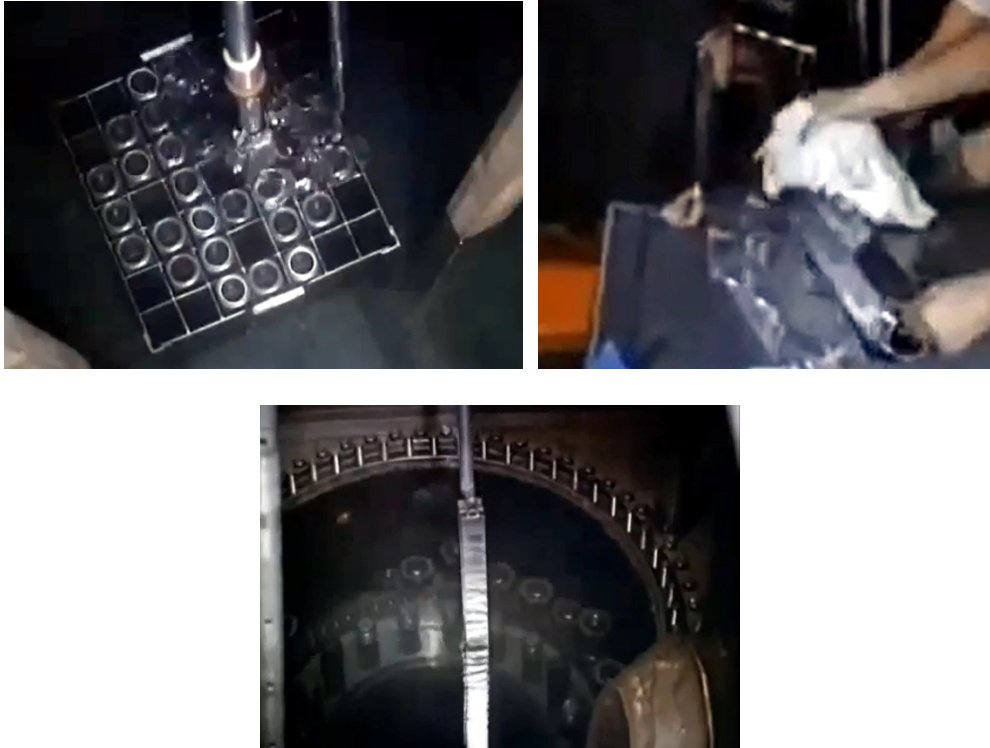

Figure 7. USA Army's Camp Century-1, Greenland, Denmark Portable Nuclear Power plant PM-2A, fuel elements and top of reactor core. Source: USA Army.

The SL-1 accident did not immediately impact the USA Army's plans for small nuclear power plants. It ordered its Portable Medium-Power reactor, operating on the Greenland ice cap, to shut down pending a review of its control rods and operating procedures.

The Gas Cooled Reactor Experiment (GCRE) was built at the USA Army Reactor Experimental Area, later called the Army Reactor Area (ARA). The GCRE was a water-moderated, nitrogen gas-cooled, direct and closed-cycle reactor. It generated 2,200 kilowatts of heat, but no electricity. The USA Army meant to develop a mobile nuclear power plant, and the GCRE was the first phase of the program, proving the principle of this reactor concept.

The work at the GCRE produced the data for a pin-type fuel design for the Army's Mobile Low Power ML-1 prototype. The entire ML-1 plant was designed to be transported either by standard cargo transport planes or standard Army low-bed trailers in separate packages weighing less than 40 tons each.

The reactor was operated remotely from a control cab at a distance of approximately 500 feet to minimize the shielding requirements. It could be moved after a 36-hour shutdown period.

The reactor was designed for ease of operation and maintenance by enlisted technicians at remote installations, for reliable and continuous operation under extreme climatic conditions, and for the rigors of shipment and handling under adverse conditions.

The ML-1 shut down after operating for a total of 664 hours. Before the ML-1 had reached all of its performance goals, the Army phased out its reactor development program around 1965.

The reactor went critical for the first time in 1961 and ran as a power plant for the first time on September 21, 1962, as the smallest nuclear power plant on record to produce electricity. It reached full-power operation on February 28, 1963, and this first run continued until March 4, 1963.

The ML-1 proved disappointing, typically operating only a few days or hours before shutting down because of leaks, failed welds, and other problems.

After its four-day March 1963 run, for instance, the crew found that the coolant, nitrogen gas, had been leaking into the moderator water. By the time of its final shut-down on May 29, 1964, the ML-1 had accumulated only 664 hours of operation.

The reason for its last failure was that operation at temperatures over 1,200°F had corroded the steel pipes containing the gas.

The ML-1 concept was too advanced for the materials available at the time.

## **EXERCISE**

1. In the SL1 reactor accident,
  - a) What is the fuel zone height in the SL-1 reactor?
  - b) What is the distance in inches that the control rods could be drawn out in the maintenance process that was safe and not enough to invite a chain reaction?
  - c) Accidentally, what is the distance over which the rod was yanked out causing a prompt neutrons criticality mode and a steam explosion?

## **REFERENCE**

1. George Voelz, "The SL-1 Reactor," Chapter 15, in: Suzan M. Stacy, ed. "Proving the Principle - A History of the Idaho National Engineering and Environmental Laboratory, 1949-1999, DOE/ID-10799, 2000.