

Chapter 1

NUCLEAR AND PLASMA SPACE PROPULSION

© M. Ragheb
12/29/2019

“Two possibilities exist: either we are alone in the Universe, or we are not.
Both are equally terrifying.”
Arthur C. Clarke

“We choose to go to the moon.”
John F. Kennedy

“If something can happen, and there is enough time for that to happen, it will happen.”
Immanuel Kant’s Critique of Pure Reason

“Imagine there is no heaven
It is easy if you try
No hell below us
Above us only sky
Imagine all the people
Living for today...”
John Lennon

1.1 INTRODUCTION

In the summer of 1950, over lunch, American physicist Enrico Fermi, in reference to alien existence, addressed his colleagues: “Don’t you ever wonder where everybody is?” This became known as the “Fermi Paradox”. The Earth is 4.6 billion years old, and we could say that that was roughly the time it took a kind of life to be capable of space travel. Our universe is approximately 13.7 billion years old. Fermi postulated that during this period of time, the galaxy should have been overrun with intelligent, technologically advanced civilizations; yet we have no evidence of this despite decades of searching. Different theories tried to answer the Fermi Paradox, including the possibility that all alien life forms in oceans below a planet’s surface, the “zoo hypothesis” which suggests that societies in our galaxy decided to not contact us to “preserve” us in the same way to how humans preserve some natural places, to prevent them from getting some kind of “disease” from humans.

Is there a “great filter” that limits the continuous existence of other forms of technological civilizations? A plausible answer is:

We are right here!
Nobody else survived to our state ...
The Filter is behind us!
Nobody is there to show us the path,
We have to blaze the trail ourselves...
As we are too early, it is our destiny to lend a helping hand to those who follow us.

Further, there could be life out there, but not as we know it.

In their role as stewards of life on Earth and perhaps in the whole known universe, humans feel an innate mission to preserve and spread life; not just their own species. With their acquired intelligence, science and technology, they feel that it is their sacred destiny to preserve life, starting with the equivalent of Noah's Arks on both the moon and Mars and on the Asteroids. In fact, with their wealth in water and rare minerals, the asteroids are prime candidates for Noah's Arks and for human colonies using their water for survival, dissociating it into hydrogen and oxygen for rocket fuel, and mining their minerals for fuel, construction, food-production and trade.

One cannot dismiss the possibility that our galaxy may be the site of artifacts and relics of numerous long dead planetary technological civilizations. Some may have engaged in interstellar travel before they died out, and most of them never left their solar systems. On habitable planets like earth, such relics and artifacts are destroyed by natural processes, and few fossils remain. In airless worlds, fossils will last longer, possibly for hundreds of millions of years. If any interstellar traveling alien civilization exists today, it must be relatively small and scattered. If we ever get to travel the stars, we may find relics. Perhaps there are even some on our moon, asteroids or other solar system planets where conditions for different forms of life developed. Deep water life, complete food chains, in complete darkness clustered around volcanic thermal vents have been identified. That is why there is such optimism about the Jupiter's moon Europa and Saturn's sixth largest moon Enceladus with possible water oceans environments.

NASA can be turned into a public enterprise and the raised funds can be invested as venture capital such as SpaceX and Blue Origin to get asteroids mining and zero-gravity manufacturing in space going full speed ahead. Commercializing space will generate an extra \$20 Trillion in GDP in less than 15 years and ensure economic dominance for the next 100 years.

Life is very precarious can be subject to extinction on Earth either from within through volcanic eruptions or viral epidemics or from astral assailants as asteroid or comets impacts from space, as we know did indeed happen in the past. It is urgent to keep backup copies of life, like we keep for files on computers, on the moon and Mars and some asteroid; protected from the possible unexpected calamities that could extinguish life on Earth.

Large amounts of chemical energy must be used in space travel to propel a space vehicle, especially out of the main pull of the Earth's gravity. The first stage of the Saturn V rocket used in the Moon missions Apollo program generated as much energy as 1 million automobile engines. The rocket engine as well as the propellant fuel must also be compact and lightweight, before the space vehicle can carry them.



Figure 1. Moon's surface facing the Earth. Source: NASA.

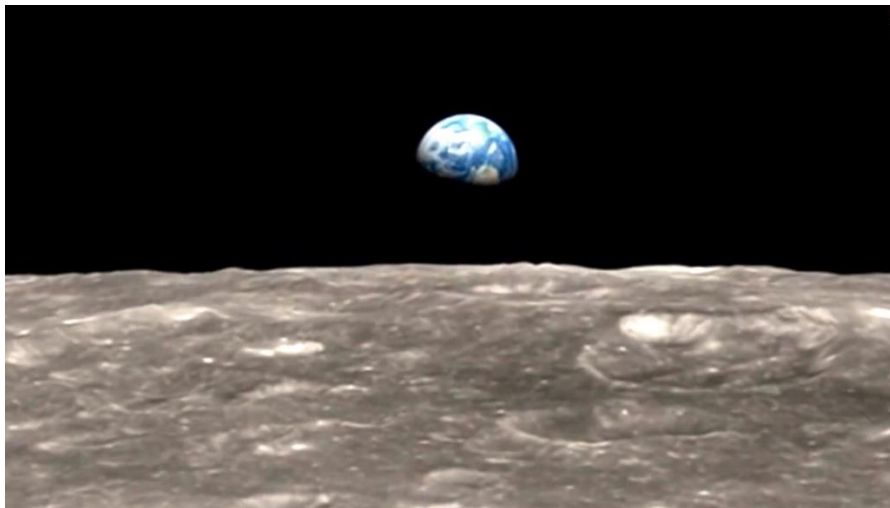

Figure 2. Earth view as a precious “blue pearl” in space from the moon. Source: NASA.



Figure 3. Apollo Mission flag on the moon. There has been 6 moon landings:
Apollo 11 - landed 20 July, 1969, Apollo 12 - landed 19 November, 1969 Apollo 14 - landed 5
February, 1971, Apollo 15 - landed 30 July, 1971, Apollo 16 - landed 20 April, 1972, Apollo 17 - landed
11 December, 1972. Source: NASA.



Figure 4. Apollo 11 boot print on the moon, July 20, 1969. Photo: NASA.

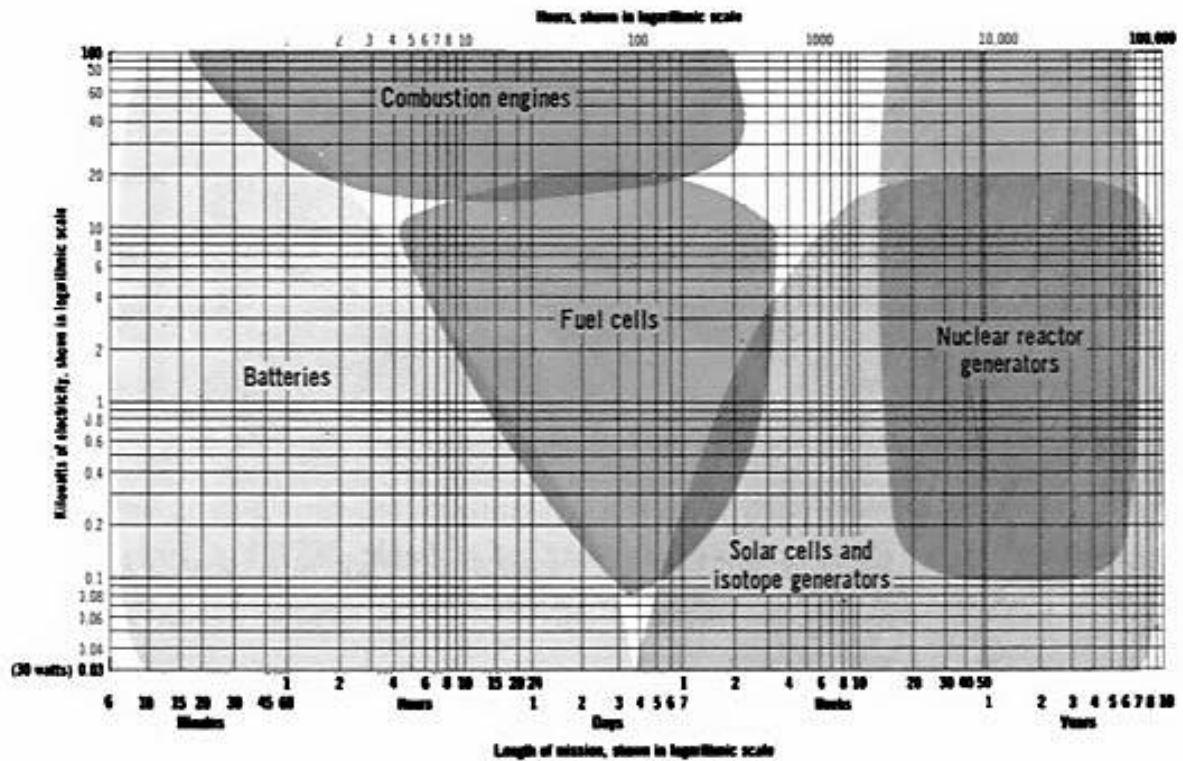

Figure 5. The power requirements versus the length of mission stay times for space missions.

The power requirements versus the length of mission stay times away from Earth favor solar and nuclear energy means. As shown in Fig. 5, for large power needs, nuclear propulsion becomes the only alternative, particularly in the deep reaches of space where solar radiation is not even available.

Christopher Conselice, Professor of Astrophysics at the University of Nottingham, found that the universe contains at least 2 trillion galaxies. The farther we look into the universe, we in fact go back in time and to the origins of the universe. Light travels at 186,000 miles per second. The light we see from distant stars, planets, and galaxies, has taken multiple light years before we can observe it. Those planets and galaxies may not even physically currently exist through merging with each other, and may have vanished for millions or billions of earth years ago.

1.2 HUMAN DESTINY AND SPACE TRAVEL

The American astronomer Frank Drake, an originator of the Search for Extra Terrestrial Intelligence (SETI) Project, suggested in 1960 an equation considering the probabilities of existence of intelligent life in the universe and estimating the probable number N of planets with Earth-like life with a technological civilization in the known universe as:

$$N = R^* \cdot P_p \cdot n_e \cdot P_l \cdot P_i \cdot P_c \cdot L \quad (1)$$

where: R^* is the number of stars systems,

P_p is the probability of occurrence of stars with planets,

n_e is the fraction of planets with habitable environments,

P_l is the probability that life has originated on a given planet,

P_i is the probability of life evolving into intelligence on a given planet,

P_c is the probability that the evolved creatures have the technology to send signals,

L is the Longevity factor.

Other factors could be added to this equation. For instance a factor possibly designated as the moon effect, P_m , can be added for the probability that a planet would possess an Earth-moon balance relationship like the existing one. It is suggested that the Earth was initially at half the size of the present planet, when a celestial object, collided with the Earth forming a double planet. A smaller body separated and orbited the larger one initially, then moved away with a decreasing orbital velocity forming the present-day moon.

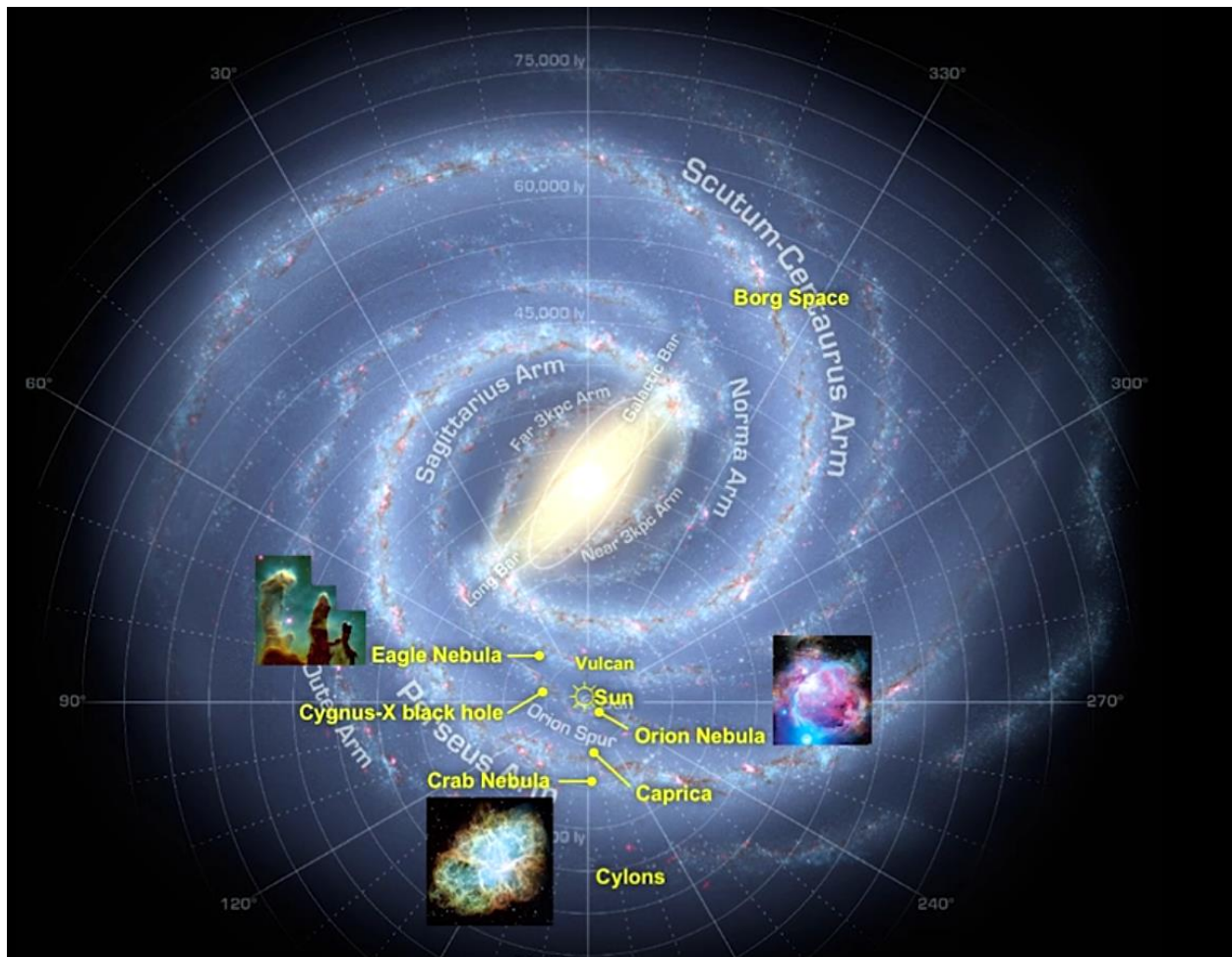

Figure 6. Milky Way galaxy.

Maybe the Earth and Mars collided in the distant past ejecting the moon in the collision, with the Earth as the larger size object keeping the Mars' water forming its oceans. It is surmised that the Pacific Ocean, may be a remnant of that collision.

Irrespective of its mode of formation, the gradually increasing drag of the moon's gravity slows down the rotational wind of the Earth, which would otherwise blow at an excess of 200 miles per hour. Such a high wind, like what presently exists on Mars, would make the Earth's surface uninhabitable by surface dwelling creatures. Incidentally, a future Mars colony may have to be built underground or carved into the sides of cliffs for this very reason. The moon tides also contribute to the molten state of the Earth's core in addition to radioactivity. The ensuing Earth's magnetic field is offering protection for life on Earth against the solar wind.

A factor P_J can be added for the so-called Jupiter Effect. Weren't it for the fact that Jupiter is the large size that it is, and has a circular orbit, Earth would not exist as far from the sun as it presently is. At 50,000 miles closer, it would be too warm and outside the livability zone. A few thousand miles farther, water would be in the frozen state like on Mars. Jupiter with its large gravitation also attracts asteroids and meteoroids from impacting Earth and causing frequent mass extinctions.

Most galaxies are subject periodical Gamma Ray Bursts (GRBs) that sterilize the whole galaxy with intense electromagnetic gamma radiation precluding any higher life forms. This would add another probability for the absence of gamma rays bursts: P_γ , and implies that most galaxies do not contain organic life.

Most yellow dwarf stars like our sun are large enough to emit solar flares of large proportions so as to reach Jupiter's orbit. Another probability P_y , would account for the fact that our sun is a yellow dwarf of just the right size so as not to destroy the Earth with its 11 or 22 years solar cycles flares.

Periodic mass extinctions are a fact of the fossil record. It is suggested that some of them were caused by cosmic collisions by comets or asteroids with the Earth. A factor P_{cc} for the probability of surviving such collisions can be added to the equation.

Thus one can suggest our own modified form of the previous equation as:

$$N' = R^* \cdot P_p \cdot n_e \cdot P_l \cdot P_i \cdot P_c \cdot P_m \cdot P_J \cdot P_\gamma \cdot P_y \cdot P_{cc} \cdot L \quad (2)$$

An optimistic view would also identify the factors in Eqn. 2 as possibilities rather than probabilities. In possibility theory, the AND logical gate implies taking the minimum of the possibilities rather than the product of the probabilities as in probability theory, yielding:

$$N' = R^* \cdot n_e \cdot L \cdot \text{Min}[\pi_p, \pi_l, \pi_i, \pi_c, \pi_m, \pi_J, \pi_\gamma, \pi_y, \pi_{cc}] \quad (2)'$$

where the possibilities π_i replace the probabilities P_i .

The only factor that is well understood in Eqns. 1 and 2 is R^* . It is thought to be equal to 100-400 billion star systems in our galaxy alone.

Other factors are needed for life to exist on planet Earth. It had to form in a stable orbit of a livability zone, not too cold and not too hot, with enough mass that its water and its atmosphere would not boil off or permanently freeze. It had to rotate at a fast enough rate that water did not freeze on the night side as it faced its star, the sun. It had to be hit by a planetoid that deposited

enough iron in its core to generate a magnetic field capable of shielding the surface from hard solar and space radiation. The remains of that collision, the moon, would be necessary to create the tides which allowed life to eventually emerge from the sea.

There is lots of terrestrial type planets in our galaxy, but most of them may look like Mars or Venus: a bit too far or too close, not enough mass, no iron core, and incorrect rotation. It may actually take an entire galaxy of random collisions and chemical reactions to produce a single planet like Earth. We may in fact be the only ones here in our Milky Way galaxy.

The Terrestrial Planet Finder (TPF) satellite experiment by detecting the light reflected from a distant rocky planet, while nullifying the light of the parent star, may gain information on the probability of occurrence of stars with planets; the P_p factor. At present, several planetary systems have been found. Geoffrey Marcey and Paul Butler have discovered two thirds of these extra-solar planets, from the University of California at Berkeley. They developed a technique to detect planets based on the gravitational pull of planets on their own sun-like stars, causing a Doppler's effect wobble in the frequency of light coming from the star.

Jill Tarter describes the present state of knowledge: "The Drake equation is a wonderful way to organize our ignorance."

Regardless, humanity's most important endeavor is in making the longevity factor L as large as possible, since humanoids have been around on Earth for only 125,000 years. As suggested by Achenbach and Essick: "It is not clear yet that a brain like ours is necessarily a long-term advantage. We make mistakes. We build bombs. We ravage our world, poison its water, foul its air."

The Optical Gravitational Lensing Experiment in 2006 detected the first evidence of a solar system about 5,000 light years away that contains two scaled down gas giant planets that are the same distance apart as Jupiter and Saturn are from our sun, leaving room for a possible planet like Earth. The detection occurred when the star orbited by the planets crossed in front of a star farther from Earth producing gravitational micro lensing. In such a situation the nearer star's gravity magnifies the light shining from the farther star. The planets' orbits of their parent star altered this magnification in a distinctive pattern. The two planets have masses that are about 71 percent of Jupiter's mass and 90 percent of that of Saturn. The parent star is about 50 percent the mass of the sun.

The astronomer Carl Sagan estimated that there could be a million technological civilizations in our galaxy alone. Frank Drake offers the number 10,000. John Oro guesses the existence of 100 civilizations in the Milky Way galaxy.

There is a possibility that their assessments are off the mark. What if N is equal to just 1 in the Drake's equation? This would mean, as suggested by Ben Zuckerman from UCLA, that we may well be alone in this galaxy, if not in this whole universe. If, as suggested here, extra probabilities or possibilities are added to the original equation, one should be amazed at how our existing form of life even exists, and that $N' = 1$ in the modified Drake's Eqn. 2 is indeed a unique precious event.

1.3 SURVIVABILITY OF HUMAN CIVILIZATION

The human race is at risk from a series of dangers of our own making, according to Prof. Stephen Hawking. The risks include the birth of artificial intelligence and robotics, nuclear war, global warming

and genetically-engineered viruses. Further progress in science and technology will create "new ways things can go wrong".

Assuming humanity eventually establishes colonies on other worlds, it will be able to survive:

"Although the chance of a disaster to planet Earth in a given year may be quite low, it adds up over time, and becomes a near certainty in the next thousand or ten thousand years.

By that time we should have spread out into space, and to other stars, so a disaster on Earth would not mean the end of the human race.

However, we will not establish self-sustaining colonies in space for at least the next hundred years, so we have to be very careful in this period."

Concerning the Fermi Paradox, its main points as formalized by Michael H. Hart, are:

1. There are billions of stars in the Milky Way similar to the sun.
2. With high probability, some of these stars have earth-like planets, and if the Earth is typical, some may have already developed intelligent life.
3. Some of these civilizations may have developed interstellar travel.
4. Even at the slow pace of currently envisioned interstellar travel, the Milky Way galaxy could be completely traversed in a few million years.
5. And since many of the stars similar to the sun are billions of years older, this would seem to provide plenty of time."

Jonathan Carroll-Nellenback suggests:

"If you do not account for the motion of stars when you try to solve this problem, you're basically left with one of two solutions, either nobody leaves their planet, or we are in fact the only technological civilization in the galaxy.

Stars orbit the center of the galaxy on different paths at different speeds. They occasionally pass each other, so, aliens could be waiting for their next destination to come closer."

He is echoing the earlier assertion by Arthur C. Clark: "Two possibilities exist: either we are alone in the Universe, or we are not. Both are equally terrifying."

It is worth noticing that we cannot assume that all advanced life is benign, and we should be glad that there are not big monster civilizations out there that make themselves known right about now. It is also possible that our as well as other electromagnetic transmissions just do not survive very far out according to the inverse square law and by attenuation through absorption and scattering in the interstellar medium. Also, we have only been broadcasting for an infinitesimal 100 years.

The earth is subjected to partial often near complete destruction by the sun over a period of 12,000 years. Human we may not be worth more than an observational experiment to any aliens. The stars that we observe may be the dying embers of a campfire that died in the distant past. Astronomers may be behaving like ants picking over the crumbs the campers dropped during dinner. Advanced civilizations may not be interested in us as we are not interested in ants under our feet in our backyards. Humans do not try to communicate with worms or bacteria, we just study them.

About 99.9 percent of all species on Earth are now extinct. If intelligent life is a one in a billion chance and additionally is destined to go extinct once it appears anyway, it might take a million galaxies to generate just one intelligent species for a very brief moment in time. If this species is a billion light years away from us, then the absence of signs of intelligent life make sense.

A pessimistic observation is that life seemed to rise up as soon as the conditions were right. One could deduce that life is everywhere that liquid water is, but that intelligent life is orders of magnitude more rare and, when it does arise, quickly destroys itself. Living beings consume other living beings for food. Would alien entities feed on humans if a connection is established, or would humans feed on aliens, and round and round we go?

Science theorizes that higher dimensions exist. If this is the case, aliens may populate these higher dimensions. Humans are trapping themselves on earth with the ever increasing amount of space junk orbiting the earth. At some point it will be impossible to fly through it. The energies involved in interstellar travel are large and would require harnessing the power of the star around which a planet orbits.

Humans may mistakenly believe that only planets that seem to be earth-like can develop or harbor life forms. Many advanced life forms may be too different from us for us to be able to understand them, let alone communicate with them. If we ever run into any extraterrestrials out there, one could not be assured of a warm, fuzzy reception from them. It could be that the universe is full of wolves, and smart species discovered that it is best to stay inconspicuously home and keep their mouths shut. Humans have a tendency to anthropomorphize. Aliens surely would have a different modus operandi than them.

As long as humanity is not able to leave the planet earth, humanity's fate is tied to the fate of its planet. Humanity has a pretty good idea about the planet's fate in the long run so it is humanity's instinct and destiny is to leave this planet to other realms.

Fossil fuels is stored energy just as electro-chemical energy is stored in a battery. When the battery runs down that energy is not available. Nuclear fission and fusion, and hopefully zero point energy as workable alternatives to running off of fossil fuels, have not yet been sustainably implemented on earth. When the battery runs down, the advanced technological civilization ends with it, as technology is knowledge applied to resources, so without part of the equation we only have knowledge with nothing to apply it to. If this is the case everywhere in the universe, civilizations as advanced as we are can flicker into existence but then die as the battery runs out before some sustainable alternative power source is discovered and implemented.

The Earth is an incredible rarity in the Universe:

Its sun providing it with light and heat is a G-type main sequence star. These are not all that common and that is the only type of star that is friendly to life.

All its sun's gas giants developed in the outer solar system. Every time astronomers have located exoplanets they have "hot Jupiters" which would ruin any chance of an earth like planet.

The gas giants in the outer solar system gravitationally vacuum up the system from asteroid and comets that could impact the earth.

Its moon is a single moon, in addition to the other system gas giants, stabilizes its axis and provide tidal forces. And the moon is of the exact right size and distance for the planet, in order for it to neither be too much or too little, a true goldilocks situation.

The planet is geologically active and have tectonic activities.

It has a lot of water that is liquid, which requires the planet to be in a narrow band around its star.

The planet is not geo-locked to the star, since without a proper day-night cycle life has no chance of emerging.

A miracle is for life and then intelligent life to form. There have been life on the planet for roughly a billion years, but it was only 50,000 years ago that humans suddenly became intelligent.

The hope exists that this intelligent life does not end up destroying itself, due to the reckless use of scarce resources or by starting an irrecoverable war.

That there is even one civilization in our galaxy is a miracle by itself. It matters little if another civilization developed in a galaxy billions of light years away. For all intent and purposes, humans are most likely, “home alone.”

1.4 UNIQUE TERRESTRIAL BIOCHEMICAL LIFE FORMS, ARSENIC ASPHALT BACTERIA



Figure 7. Mono Lake, California contains arsenic-eating bacteria. Photo: Henry Bortman.

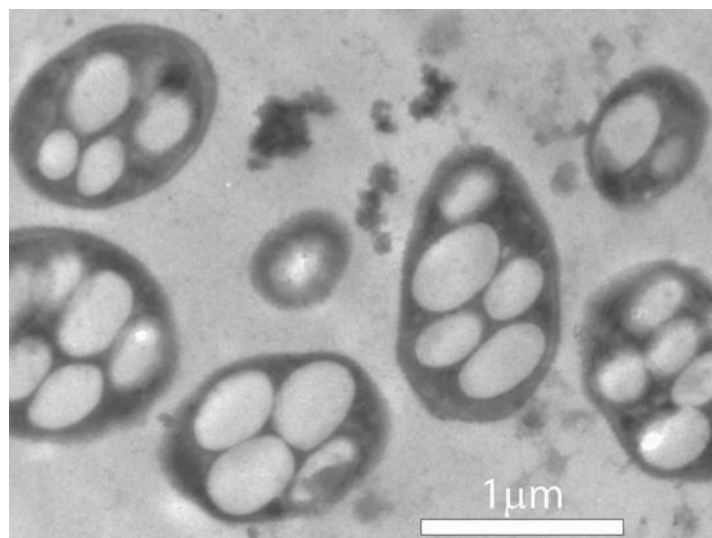

Figure 8. Transmission Electron Microscope (TEM) of cyanobacteria GFAJ-1. Source: Science, AAAS.

According to Wikipedia: “The element silicon has been much discussed as a hypothetical alternative to carbon. Silicon is in the same group as carbon on the periodic table and, like carbon, it is tetravalent. Hypothetical alternatives to water include ammonia, which, like water, is a polar molecule, and cosmically abundant; and non-polar hydrocarbon solvents such as methane and ethane, which are known to exist in liquid form on the surface of Titan.”

Bacteria in California's Mono Lake were discovered to incorporate arsenic, which is usually toxic for other life forms, into their cells. The arsenic bacteria also did not arise independently from the other organisms on Earth. Like all microbes, they multiply best when there is enough phosphorus around. They only use arsenic when there is not sufficient phosphorus.

The idea turned out to be too good to be true, as two studies published by Science that refuted the claim showed in the summer of 2012. Both showed that the microbe, discovered in California's Mono Lake, in fact seems to need some minuscule amount of phosphorus to survive. “It's just tough, not completely alien, in its biochemistry.” The arsenic bacteria are a wonderful example of the adaptability of microorganisms. What does this discovery mean for the search for extraterrestrial life-forms?

The arsenic bacteria help us broaden our horizons. If we can find such exotic organisms on Earth, we have to free ourselves from the idea that life-forms will resemble what we know from Earth. Our fixation with the idea that oxygen is essential to life may be short-sighted. This aggressive element inflicts damage to our cells in the form of free radicals. Maybe organisms elsewhere in the universe have found a gentler alternative. When we send space probes to other worlds, we should expect the unexpected with life appearing anywhere: in cold climates, toxic oceans or in hot clouds.

Arsenic-eating microbes could probably feel very at home on Mars as its conditions may be suitable to them. Measurements collected by landing robots on Mars could be interpreted as evidence of bacterial life. It could be that any life-forms on Mars are not actually aliens, but are related to us. About 4 billion years ago, Mars was a planet well suited to sustaining life, with massive rivers and lakes. At this time, the first primitive organisms appeared on Earth. These single-cell life-forms may have made it to our neighboring planet Mars by way of meteorites and established themselves there. Descendants of these primitive bacteria could have survived in nooks and crannies on Mars until today. The opposite possibility is that life could have started on Mars and then, via a collision between Mars and Earth or by a meteorite encounter made its way to Earth.

The distant Titan, a moon of Saturn has a surface temperature of minus 160 °C or minus 256 °F, and its atmosphere contains no oxygen. Its lakes are filled with liquid natural gas and liquid methane CH₄ rains from the sky, and it looks like the aftermath of an oil spill in the Antarctic. If life exists there, it would look different from life on Earth.

At the Caribbean island of Trinidad, there is a natural asphalt reserve called Pitch Lake, which is fed by oleaginous substances from the Earth's crust. It is a tourist attraction with its conditions similar to that of a lake on Titan. Masses of bacteria which transformed long-chain hydrocarbons into methane in the asphalt lake were detected in it. These bacteria manage to survive with practically no water.

The discovery of the arsenic bacteria and the asphalt bacteria show that when life has found its way to a planet, then it will find a biochemical way to survive.

1.5 DEEP OCEAN LIFE FORMS

Microbes are thriving at the deepest spot in the oceans, the 11,000-meter or 36,000 ft Mariana Trench in the Pacific. The Mariana Trench is 5 times longer than the Grand Canyon, USA, and could contain the world's highest mountain Mount Everest, which stands 8,848 meters in height. The bottom of the Mariana Trench was first reached in a submarine in 1960. Dead plants and fish are falling to the Hadal Depths; parts of the seabed deeper than 6,000 meters and named after Hades, the god of the underworld in Greek mythology.

The presence of life in the Mariana Trench shows how the greenhouse gas CO₂, vital for the growth of tiny marine plants at the ocean surface, eventually get buried in the depths in a natural process that slows climate change. This backs up a theory that dead plants and fish falling onto the steep sides of the Mariana Trench often slide to the bottom to form a hot spot for microbial life. Earthquakes also trigger mudslides that carry the top debris to the bottom.

A few shrimp-like crustaceans were spotted at the bottom of the Mariana Trench. Only about 2 percent of the world's oceans are deeper than 6,000 meters. Waters at these depths are just above freezing. Only 1-2 percent of living material in the upper waters is expected to sink even to the average ocean floor depth of 3,700 meters. Most food gets scavenged and carried up towards the surface before it falls to the greater depths.

Water pressure at the bottom of the trench is about 16,000 psi or 1,125 kg / cm². The ability to survive crushing depths may mean that the bottom dwelling creatures have special enzymes that allow them to survive at such low temperatures and high pressures.

1.6 NUCLEAR ROCKET PROPULSION CONCEPTS

The nuclear rocket involves a combination of the principles of rocketry and nuclear reactor technology. Most of them involve the delivery of energy as heat or kinetic energy to the rocket itself or to a working medium such as liquid hydrogen. The working medium is then expanded through a nozzle and accelerated to high ejection velocities reaching 6,000 to 10,000 m/sec.

The heating of the gas is not achieved by chemical reactions like in chemical rockets, but from nuclear reactions including fission, radioactive decay, fusion, and miniature nuclear explosions. In chemical rockets, energy is obtained from the propellants themselves, whereas in nuclear rockets the energy source and the propellant are separate.

Several concepts have been proposed:

1. Nuclear Thermal Propulsion (NTP):

In this case a fission reactor produces the energy generated from the fission of uranium. This energy is transferred to liquid hydrogen as a working fluid. The reactor core operates at high temperature above 2,200 degrees Celsius. A diagram of a solid core reactor thermal system is shown in Fig. 9.

Many concepts for both the power generation and the propulsion aspects are under consideration. These include solid liquid and gaseous fuel reactors and liquid metal and gas cooled reactors. Solid core reactors include pellet beds, particle beds, wire core, and foil reactors. Liquid cores include a droplet core and a liquid annulus core. Gaseous cores include an open cycle, a

vapor core and “light-bulb” concepts. Thermal to electric conversion cycles include dynamic cycles: Potassium Rankine and Brayton, as well as static cycles: thermionic and HYTEC.

2. Nuclear Electric Propulsion (NEP):

The nuclear electric power generated from the fission reaction or from the decay of radioisotopes is used to accelerate ions or other subatomic particles, which are ejected from the back of the rocket providing in a continuous low thrust. Such a system is shown in Fig. 13, together with the other components of the nuclear electric vehicle including the payload, shield, radiators, thrusters, power conversion, and power conditioning equipment. The propulsion concepts include steady state and pulsed electromagnetic engines, pulsed electrochemical and steady state electrostatic engines.

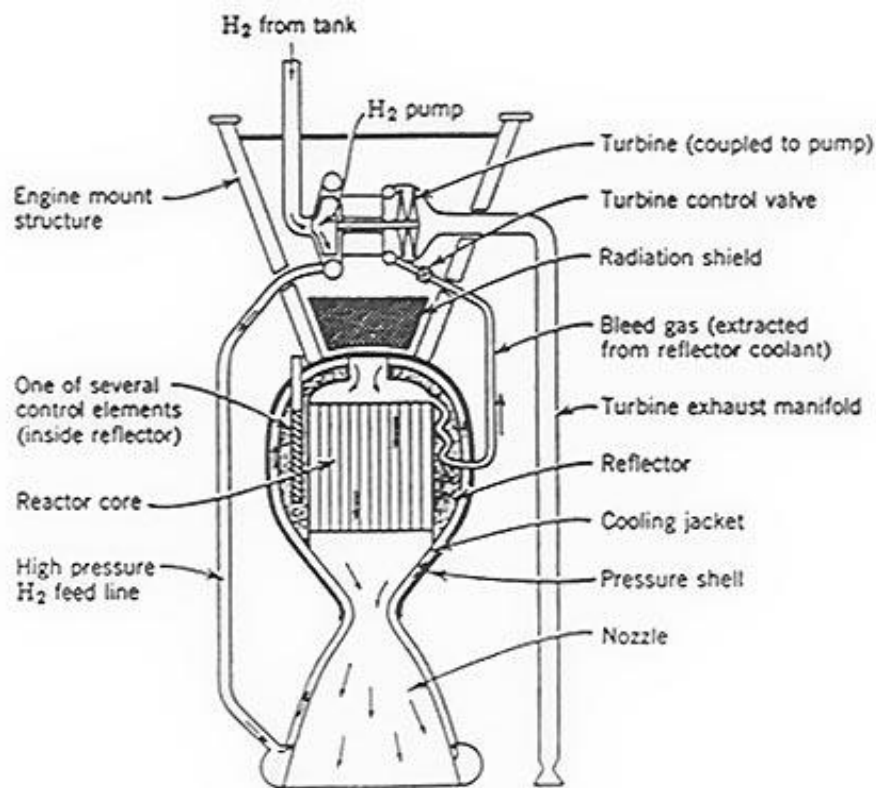

Figure 10. Solid Reactor Core for Nuclear Thermal Propulsion, NPT.

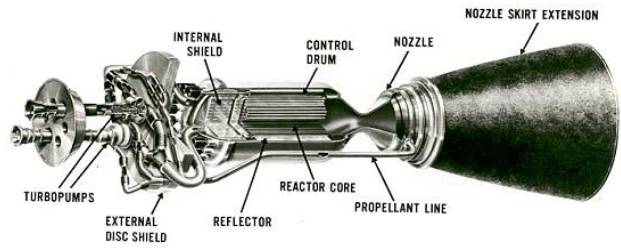

Figure 11. NERVA solid core rocket design.

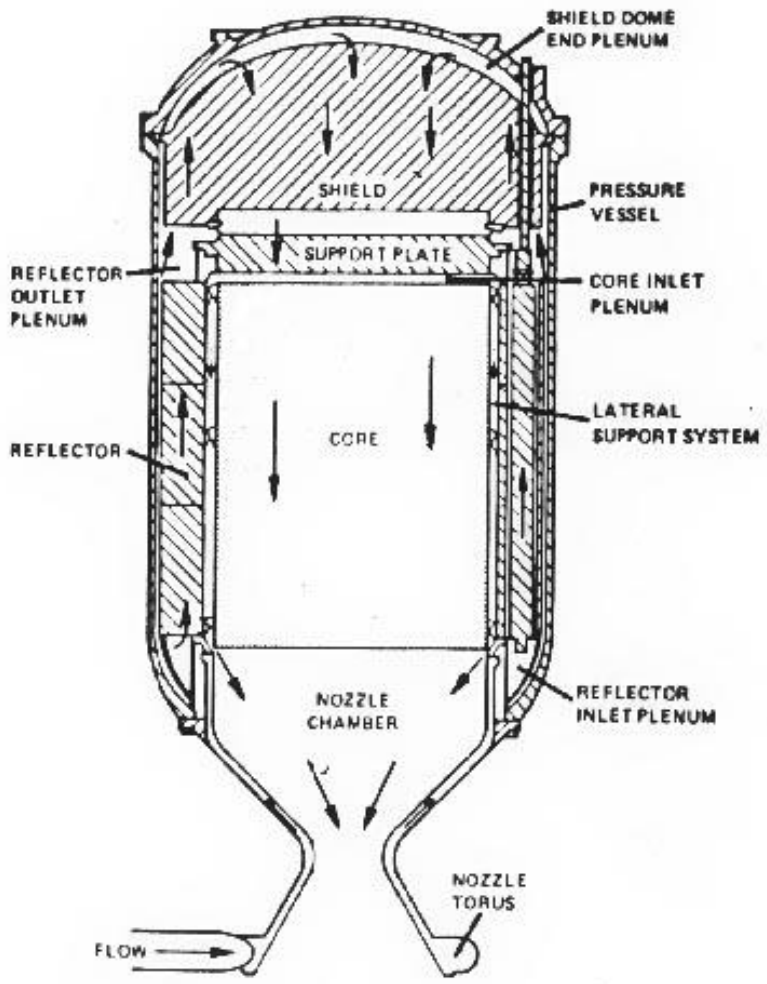

Figure 12. Reactor of solid core rocket.

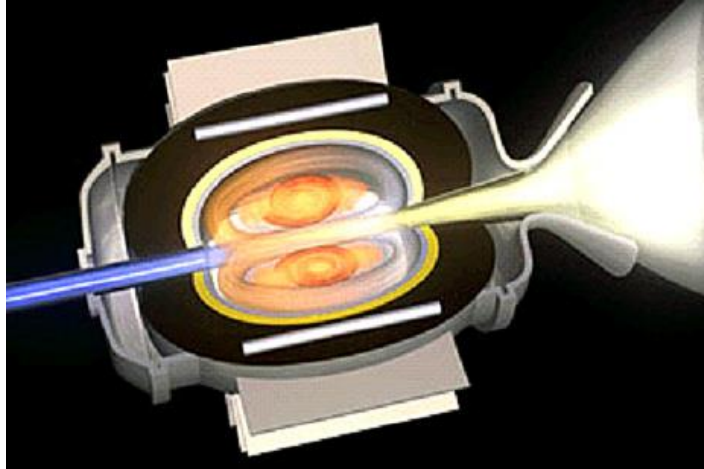

Figure 13. Gaseous reactor core rocket. Source: LANL.

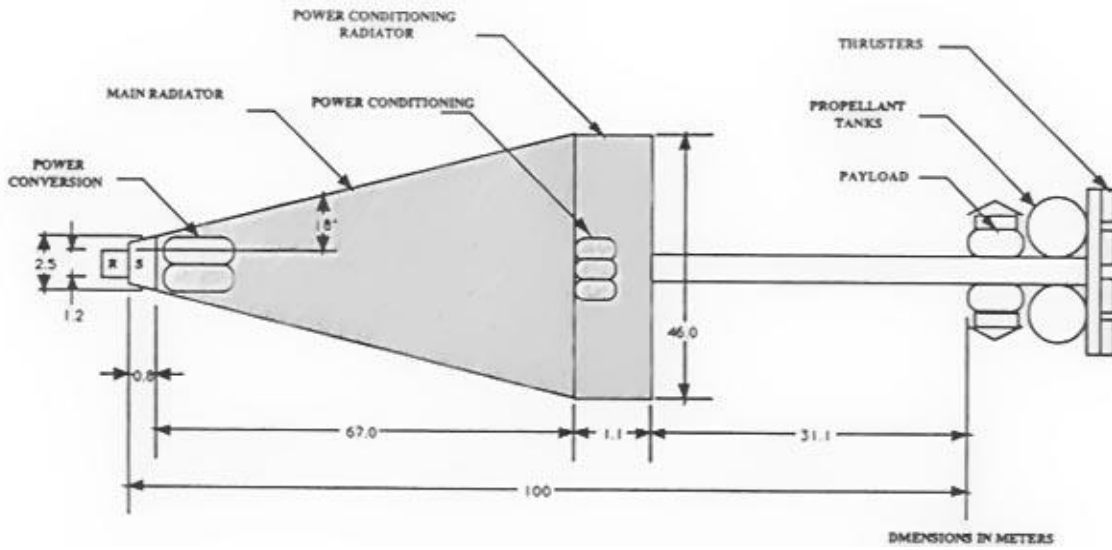

Figure 14. Schematic of Nuclear Electric Propulsion, NEP Vehicle and System.



Figure 15. Prometheus ion thruster conceptual design. Source: NASA.

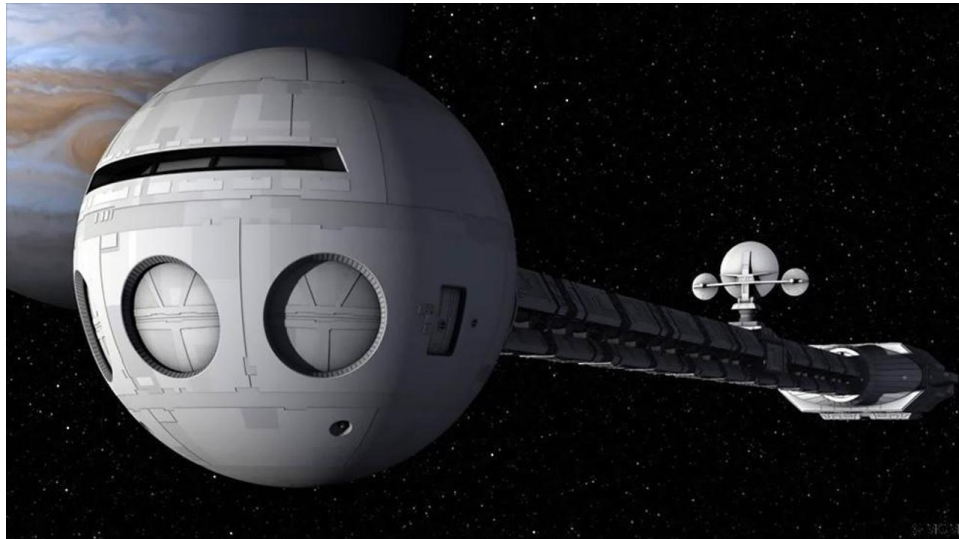

Figure 16. 2001: Space Odyssey; Arthur Clark's book turned into a movie. The crew quarters are positioned on a beam with shadow shielding away from the nuclear rocket engine. Source: MGM.

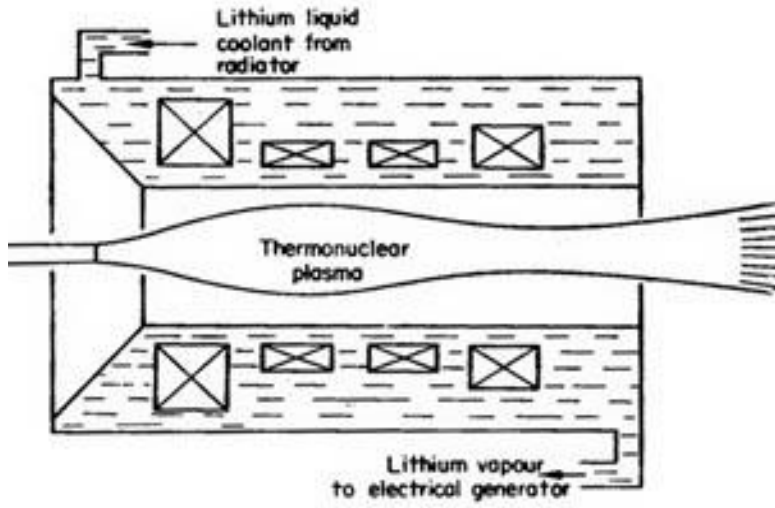

Figure 17. Schematic of a nuclear fusion rocket.

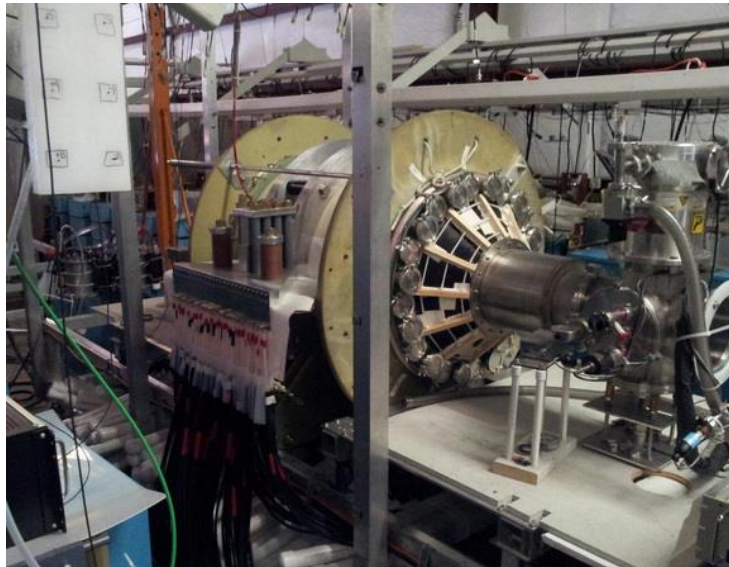

Figure 18. Fusion rocket experiment. Source: Univ. of Washington.

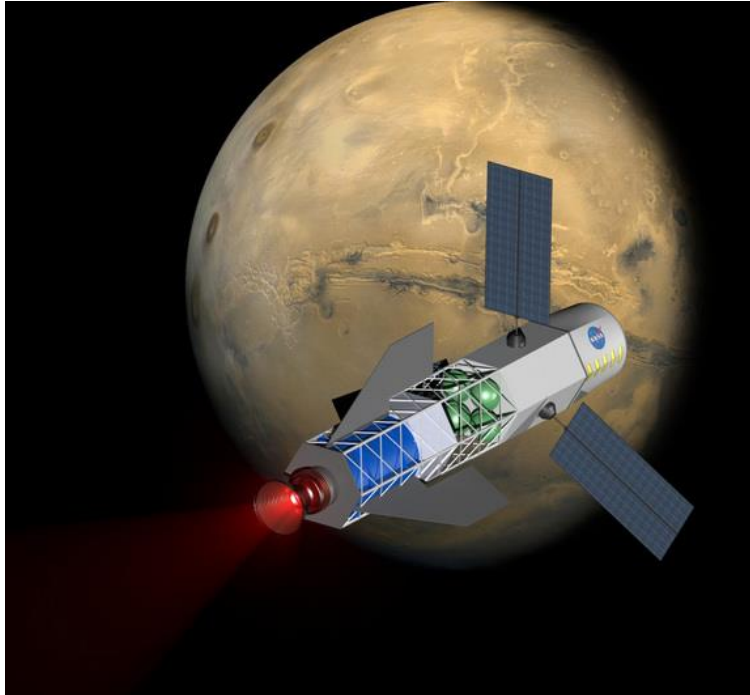

Figure 19. Fusion rocket for a Mars mission. Source: Univ. of Washington.

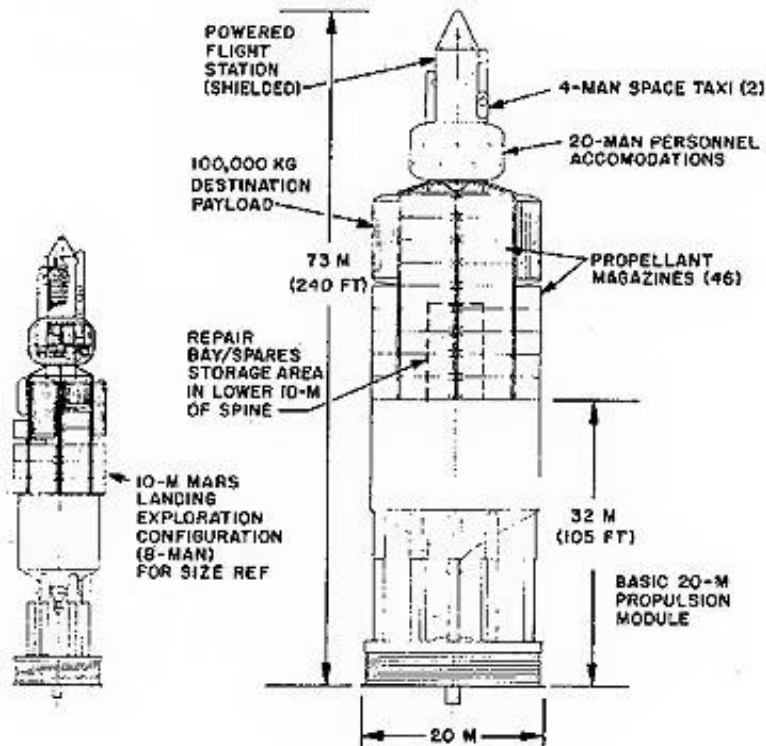
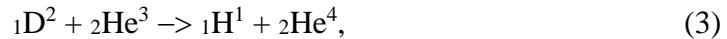

Figure 20. Mars exploration modules based on External Pulsed Plasma Propulsion, EPPP for a Mars mission. The spacecraft could take off from Earth and travel to Mars and back in just three

months. The quickest flight using conventional rockets and the right planetary alignment is 18 months.

3. Nuclear Fusion Propulsion:

In this case, nuclear fusion using charged particles fusion reactions such as the reaction:



would produce only charged particles whose kinetic energy can be directed by a magnetic field from a nozzle at the back of the engine. Figure 17 shows a schematic of a fusion propulsion system including a thermonuclear plasma enclosed in a magnetic mirror generated by the conducting magnet coils surrounding the plasma.

4. External Pulsed Plasma Propulsion, EPPP:

This concept using miniature nuclear explosive charges has been explored in the past and designated as the Orion project. The charges are ejected in the back of the rocket, and their energy is transferred to spring loaded plates at the back of the rocket. Figure 20 shows schematics of such a concept studied for a Mars mission.

1.7 NUCLEAR ROCKET PROPELLANTS

In chemical rockets, the same materials perform the functions of working medium and energy source. The energy content of the reactant is controlled by the strength of the chemical bond. It becomes a major consideration limiting the rockets specific impulse to 500 lbf.s/lbm for optimal combinations of hydrogen with oxidants such as ozone, fluorine and oxygen. The choice of a chemical propellant is restricted by the propulsion parameters. Propellant mixtures of low specific gravity are favored from this perspective.

In nuclear fission rockets, the propellant coming in proximity with the fission fuel must exhibit a low absorption cross section for neutrons. Table 1 shows the absorption cross section of some possible propellants. Low neutron absorption eliminates lithium and boron. Helium and beryllium face cost and handling problems. Thus hydrogen appears as a superior choice for fission rocket propulsion.

On the opposite end in fusion rockets, a significant amount of the energy may be: carried away by neutrons such in the DT fusion reaction:



In this case the neutrons carry 80 percent (14.06 MeV) of the energy release (17.6 MeV). Thus elements with a high absorption cross section such as lithium would be favored in this case. It would have to be introduced away from the plasma itself into the fusion products at the downstream end of the reaction zone. If it contaminates the plasma it would quench the fusion reaction through emission of bremsstrahlung x-ray radiation, and in the presence of a magnetic field in the form of synchrotron radiation.

Table 1. Properties of some possible nuclear propellants.

Propellant	Thermal neutron absorption cross section (barns)	Atomic Mass (amu)
H	0.33	1.0079
He	0.0008	4.00260
Li	71.0	6.941
Be	0.005	9.01218
B	750.0	10.81
C	0.0045	12.011
N	1.7	14.0067
O	0.0006	15.9994

Hydrides can also be used. Water is one of them, but it dissociates into hydrogen and oxygen at high temperature exceeding 2,500 Kelvin. In addition it is highly corrosive as high temperature steam. Other hydrocarbons can be used giving a dissociated molecular weight around 8 at high temperature and pressure. The nitrogen hydrides ammonia and hydrazine give dissociated molecular weights of about 10, but present a health hazard.

For a trip to Mars, water stored under its surface as permafrost could be mined for the return trip in a nuclear rocket, and its use needs careful investigation.

1.8 ROCKET PARAMETERS

Rocket propulsion combines the principles of mechanics, thermodynamics and in the present case, nuclear science. Propulsion is achieved by applying a force to a vehicle to accelerate it. Alternatively it involves the application of a steady velocity against a resisting force. The propulsive force is achieved by ejecting a propellant at high velocity creating thrust.

The *total impulse* I_t is considered as the time integral of the thrust force $F(t)$:

$$I_t = \int_0^t F(t) dt \quad (5)$$

The time t is the burning time of the rocket, and the thrust force $F(t)$ is a function of time.

In rocket engines, the propellant or working fluid is carried aboard the vehicle being propelled. Accordingly, the duration of the mission is limited by the mass of the propellant carried. This imposes a premium on the rocket's *specific impulse* I_s defined as the ratio of the total impulse per unit weight w of the propellant:

$$I_s = \frac{\int_0^t F(t) dt}{w} \quad (6)$$

where the total weight of the propellant in terms of the mass flow rate is given by:

$$w = g_0 \int_0^t \dot{m}(t) dt$$

$g_0 = 980.66 \text{ m/sec}^2$ or 32.16 ft/sec^2 , is the gravity acceleration at sea level.

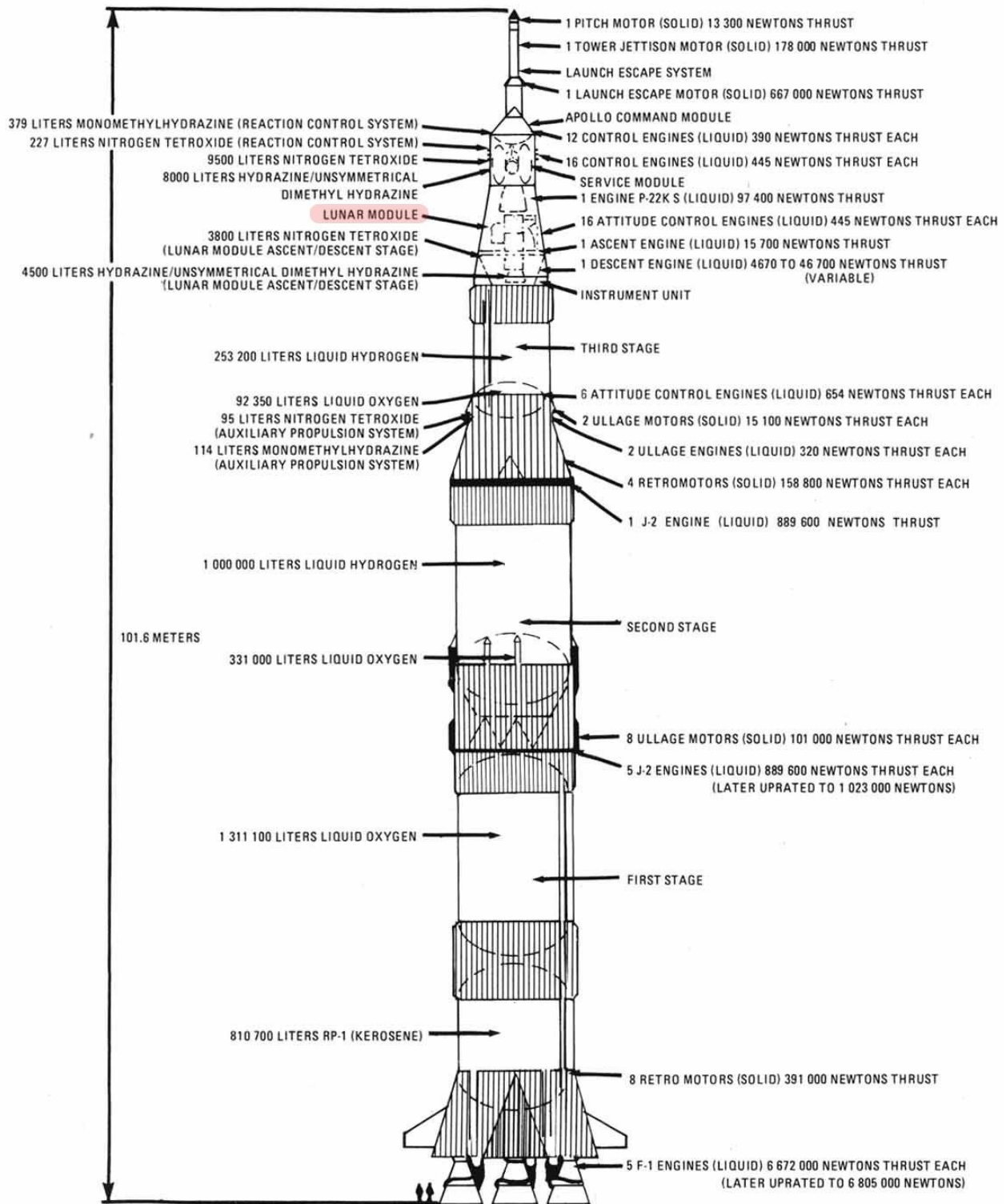

Figure 21. Saturn V rocket used in Apollo Program missions to the moon. Source: NASA.

For constant thrust force F and propellant flow, this equation can be simplified as:

$$I_s = \frac{F.t}{g_0 m_p} = \frac{F}{g_0 \dot{m}} = \frac{F}{\dot{w}} = \frac{I_t}{w} \quad (7)$$

This equation identifies the specific impulse as the total impulse $F.t$, per unit weight of the propellant $g_0 m_p$.

The specific impulse I_s is also called the *specific thrust* since in fact it is the total thrust I_t per unit weight w of propellant.

The units of the specific impulse in the Système International (SI) system of units is:

$$\frac{\text{Newtons}}{\frac{\text{m}}{\text{sec}^2} \cdot \frac{\text{kg}}{\text{sec}}} = \frac{\text{kg} \cdot \frac{\text{m}}{\text{sec}^2}}{\frac{\text{m}}{\text{sec}^2} \cdot \frac{\text{kg}}{\text{sec}}} = \text{sec}.$$

The *effective exhaust velocity* is the average equivalent velocity in m/sec, at which the propellant is ejected from the rocket. It is given by:

$$v_{eff} = \frac{I_s}{g_0} = \frac{F}{\dot{m}} \quad (8)$$

The *specific propellant consumption* is the reciprocal of the specific impulse. It is the required propellant weight flow to produce a unit of thrust force in an equivalent rocket. Its units are kgs per kg.second. It is expressed in terms of the ratio of propellant flow rate to the thrust:

$$\text{Specific propellant consumption} = \frac{1}{I_s} = \frac{\dot{w}}{F} = \frac{\dot{m} g_0}{F} \quad (9)$$

The *impulse to weight ratio* of a complete propulsion system is defined as total impulse I_t divided by the initial vehicle weight or propellant loaded vehicle weight. A high value suggests an efficient design of the rocket. It is given by:

$$\text{Impulse to weight ratio} = \frac{I_t}{w_0} = \frac{I_s t}{(m_f + m_p) g_0} = \frac{I_s}{\left(\frac{m_f g_0}{t} + \dot{m} g_0\right)} \quad (10)$$

Where m_f is the final mass of the rocket after exhausting its propellant, and m_p is the propellant mass.

The *thrust to weight ratio* describes the acceleration in multiples of the gravity acceleration that the engine is capable of giving to its own loaded propulsion system mass.

$$\text{Thrust to weight ratio} = \frac{F}{w} \quad (11)$$

The *propellant mass fraction* is defined as:

$$\zeta = \frac{m_p}{m_0} = \frac{m_0 - m_f}{m_0} = \frac{m_p}{m_f + m_p} \quad (12)$$

This fraction describes the quality of the design. A value of 0.95 means that only 5 percent of the mass of the rocket is hardware that is used to contain and burn a larger mass of propellant. The final mass does not include non propulsion system components such as telemetry, communications and guidance instruments.

The *mass ratio* of a rocket or a stage is defined as the ratio of the final mass after the propellant has been consumed to the initial mass of the rocket:

$$\text{Mass ratio} = \frac{m_f}{m_0} \quad (13)$$

As an example, we consider a rocket with the parameters given in Table 2:

Table 2. Typical Rocket parameters.

Characteristic	Value	Units
Initial mass m_0	2,000	kg
Final mass, m_f	1,300	kg
Payload and structure	1,100	kg
Duration of operation, t	30.0	sec
Specific impulse of propellant, I_s	2,400	N-sec ³ /kg.m, sec

The mass ratio of the overall vehicle from Eqn. 13 is:

$$\text{Mass ratio of vehicle} = 1,300 / 2,000 = 0.65$$

The mass ratio of the rocket system is:

$$\text{Mass ratio of rocket system} = (1,300-1,100) / (2,000-1,100) = 200 / 900 = 0.222$$

The rocket propellant mass fraction is from Eqn. 12:

$$\zeta = (900-200) / 900 = 0.778$$

The propellant mass is:

$$m_p = 2,000 - 1,300 = 700 \text{ kg.}$$

The propellant mass flow rate is:

$$(m_p/t) = 700 / 30 = 23.3 \text{ kg/sec}$$

The thrust is :

$$F = I_s.(m_p/t) = 2,400 \times 23.3 \times 9.80 = 540,800 \text{ Newtons.}$$

The thrust to weight ratio of the vehicle is:

$$\begin{aligned} \text{Initial } F/w_0 &= 540,800 / (2,000 \times 9.80) = 28, \\ \text{Final value} &= 540,800 / (1,300 \times 9.80) = 43. \end{aligned}$$

The maximum acceleration of the vehicle is:

$$a_{\max} = 43 / 9.80 = 421 \text{ m/sec}^2.$$

The effective exhaust velocity becomes:

$$v_{\text{eff}} = I_{sg0} = 2,400 \times 9.80 = 23,520 \text{ m/sec.}$$

Total impulse is:

$$I_t = I_{sw} = 2,400 \times 700 \times 9.80 = 1,640,600 \text{ N.sec.}$$

The impulse to weight ratio is:

$$I_t/w_0 = 540,800 / [(2,000 - 1,100) \times 9.80] = 187.$$

Rocket engines produce thrust by transforming a working fluid to a gas by subjecting it to high temperatures and then expelling it at high velocity through a nozzle. In chemical rocket systems, the propellants as fuel and oxidizer themselves provide the energy source, and are raised in temperature by the heat of combustion.

In a nuclear rocket, the heat is supplied by a nuclear reactor, which heats the propellant that is being exhausted from the nozzle. Given an equivalent energy release to the propellants used in both the chemical and nuclear system, hydrogen if used in a nuclear rocket would provide 3 times the specific impulse generated in the chemical system. Table 3 shows the specific impulse advantage of different nuclear rocket concepts compared with chemical propulsion.

A hydrogen-oxygen mixture propellant is normally selected for the upper stage chemical engines in planned space missions. Since in a nuclear rocket, energy is generated by the fission process, liquid hydrogen alone can be used.

Table 3: Comparison of the Characteristics of Rocket Propulsion Systems.

Concept	Specific Impulse	Mars trip duration	Working Fluid	Fuel	Temperature [K]

	[sec]	[days]			
Chemical-solid or liquid bipropellant	200 - 400		H ₂ and O ₂	N ₂ H ₄	2,773 - 4,573
Liquid monopropellant	180 - 240		N ₂ H ₄	N ₂ H ₄	1,273 - 1,573
Solar heating	400 - 700		H ₂	-	1,573
<u>Nuclear Solid Core</u>					
Nerva	825 - 850	434		Duplex	2,270
Enabler	925 - 1,080			UC-ZrC-C	2,700 - 3,300
Cermet	832			UO ₂ -W	
Wire core	930			UN-W	3,030
Advanced Dumbo	-			UC-ZrC	2,700 - 3,300
Pellet bed	998			UC-TaC	3,100
Particle bed	1,000-1,200	434		UC-ZrC	3,000 - 3,500
Low pressure	1,050-1,210			UC-ZrC	3,000 - 3,600
Foil reactor	990			UO ₂	2,700 - 3,400
<u>Nuclear Liquid Core</u>					
Liquid annulus	1,600-2,000				3,000 - 5,000
Droplet core	1,500-3,000	200			5,000 - 7,000
<u>Gaseous Core</u>					
Open cycle	5,200	60-80		U plasma	
Vapor core	1,280	310		UF ₄ -HfC	6,000 - 8,000
Lite bulb	1,870				7,200
Electrothermal arc heating	400 - 2,000		H ₂		5,773
Electrostatic ion	4,000 - 25,000		Cs		-
Magnetoplasma	3,000 - 15,000		H ₂		-
<u>External Pulse Plasma Propulsion (EPPP)</u>					
Fission	5,000 - 10,000		-	Fission plasma	
Fission/Fusion, Fusion	100,000			Fission / fusion, fusion plasmas	

1.9 SPACE REACTOR EXPERIMENTS:

Named after the Kiwi, a flightless New Zealand bird, a reactor was built and operated as a rocket engine. It is shown while transported on its rail from the assembly building to the test cell in Fig. 22. The reactor was operated at high power at a predetermined temperature level and duration representative of an operational cycle.

At the University of Florida's Innovative Nuclear Space Power and Propulsion Institute, research was being conducted on advanced reactor fuels for space propulsion. The research focused on interlocked wafers of tricarbide nuclear fuel consisting of Uranium, Zirconium, and Niobium Carbide. High quality solid solution tricarbides with less than 5 percent porosity have been produced. Optimum processing parameters for producing hypo stoichiometric tricarbides are being identified. The high melting point, high power density, marked corrosion resistance of this fuel could yield significant improvements in thrust to weight and specific impulse over NERVA/Rover nuclear thermal rocket designs.

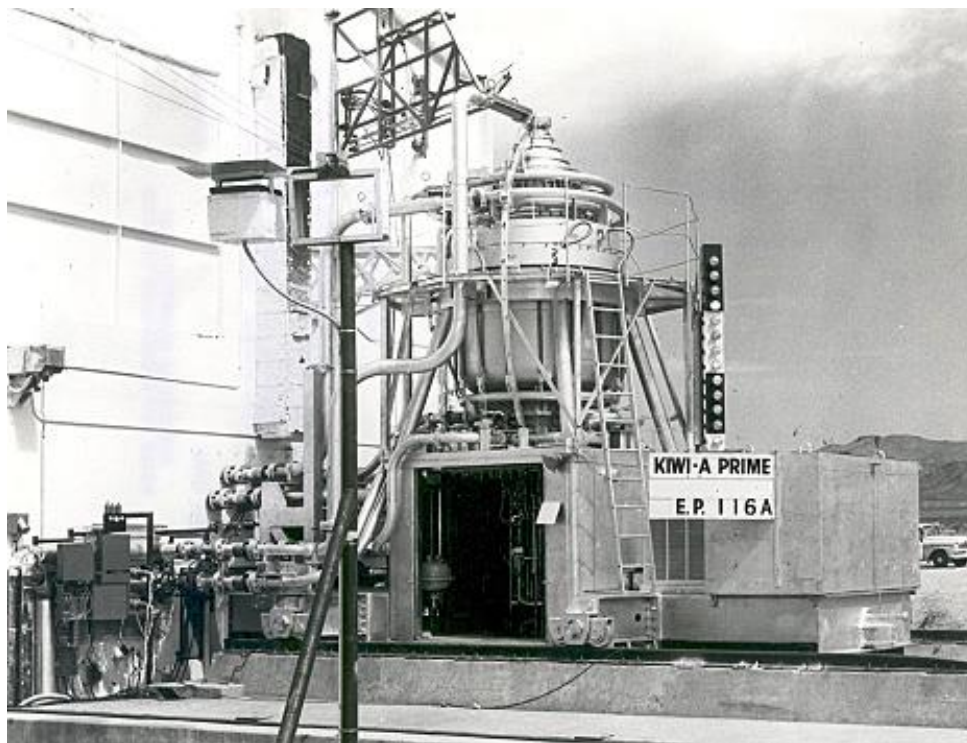

Figure 22. KIWI-A Prime nuclear rocket engine.

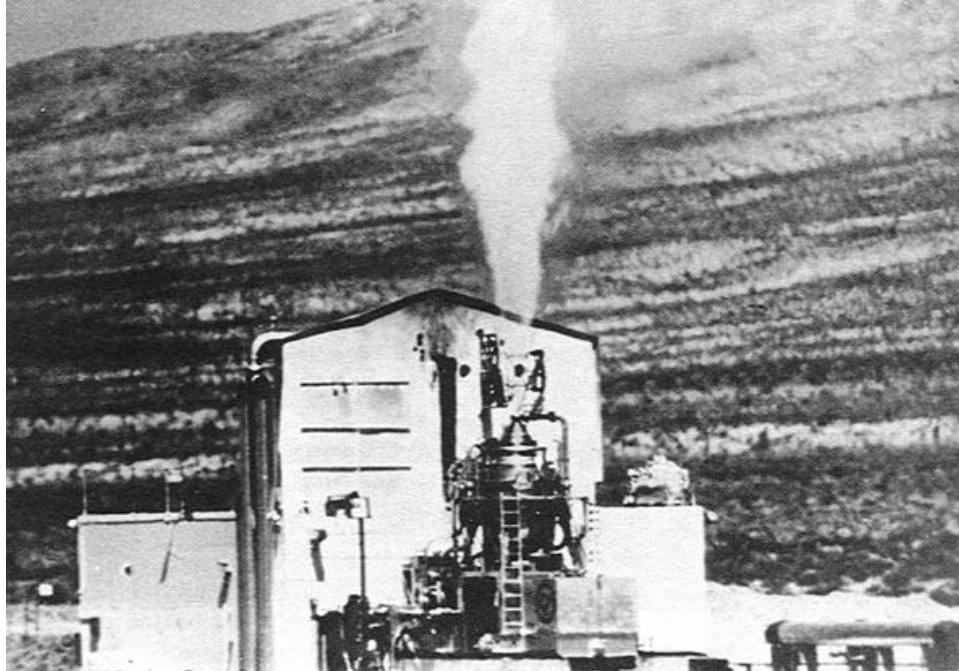

Figure 23. The Kiwi-A space reactor being tested at high power.

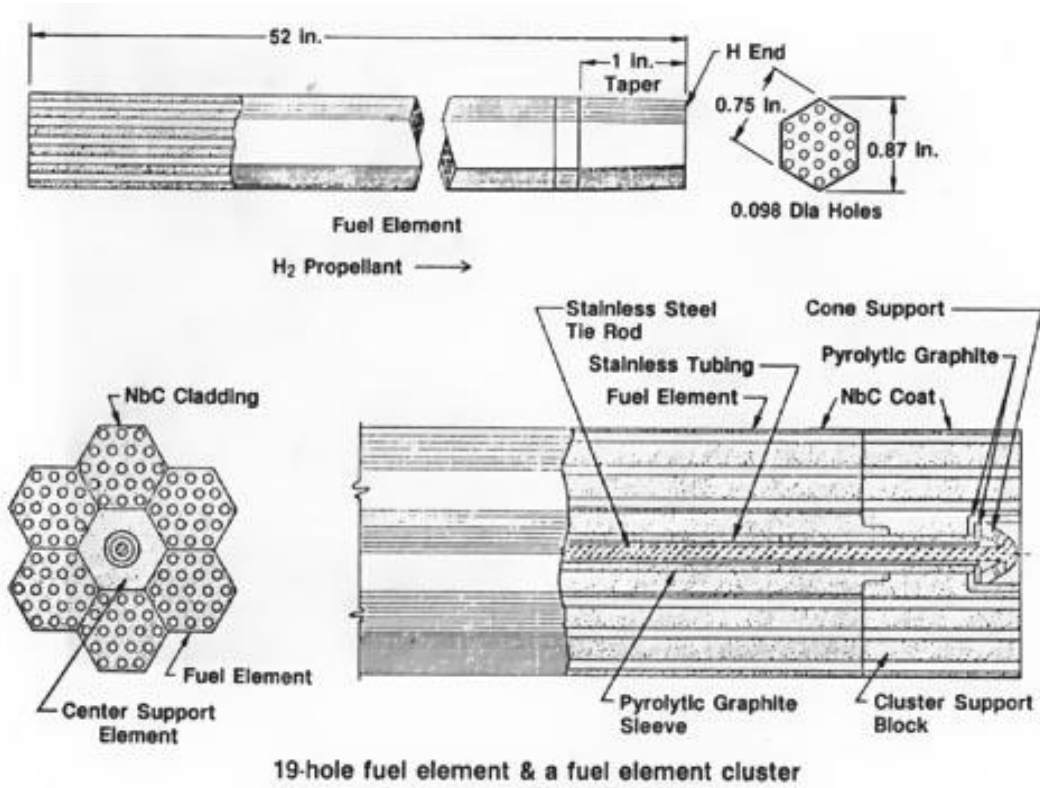

Figure 24. The KIWI B-4A Fuel Element Cluster.

The Aerojet Company conducted the first nonnuclear demonstration of a Liquid Oxygen (LOX) Augmented Nuclear Thermal Rocket (LANTR). This idea could more than triple the thrust-to-weight ratio of a nuclear thermal rocket via the injection and supersonic combustion of oxygen in the rocket's nozzle. Thrust augmentation of up to 44 percent is attained. Tests with inert nitrogen injection confirm that half the thrust increase is due to combustion of the oxygen.

At NASA-Marshall research center and Los Alamos National Laboratory (LANL), research involved the development of nuclear systems for electric and bimodal propulsion applications. Tests involving simulated fuel and heat pipe modules and reactor cores using high performance electric heaters were conducted. An entire 30-kW core was successfully operated. End-to-end demonstration of a simulated nuclear electric propulsion system at the Jet Propulsion Laboratory (JPL) were planned using this core, a compact power converter, and a small ion thruster. Testing began of flight demonstration modules for a 300-kW reactor core. Sandia National Laboratory contributed a flight experiment design study centering on this reactor configuration.

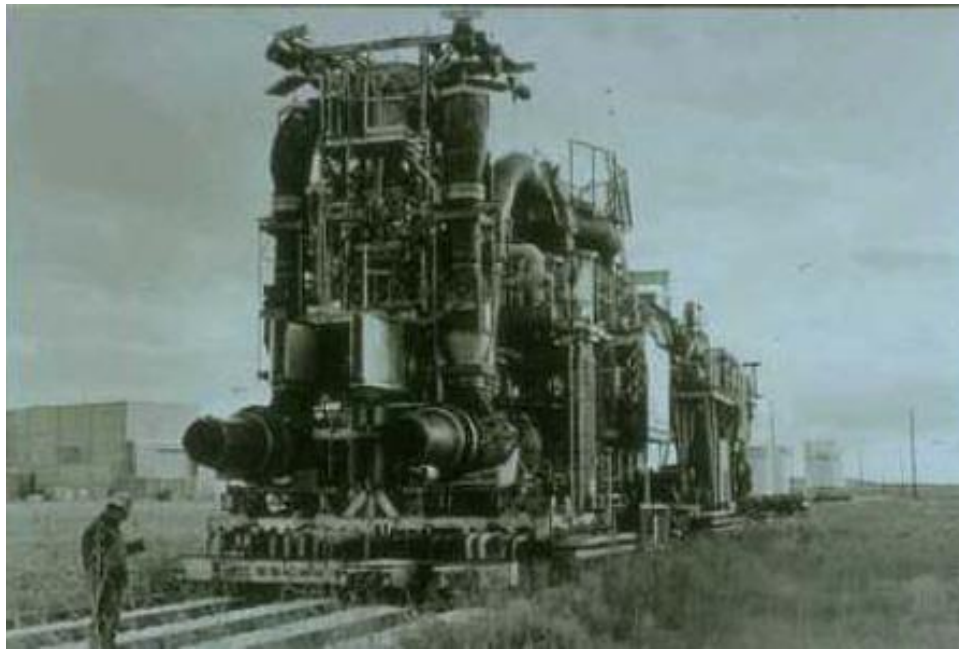

Figure 25. Nuclear Jet airplane engine at Idaho National Engineering Laboratory (INEL).

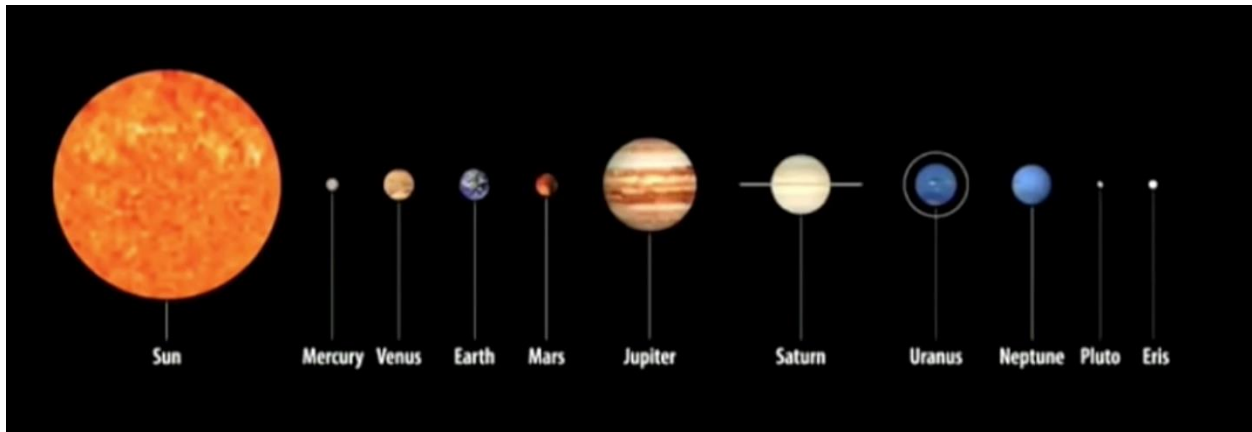

Figure 26. Comparison of solar system planets' sizes. Source: NASA.



Figure 27. Options for space travel.

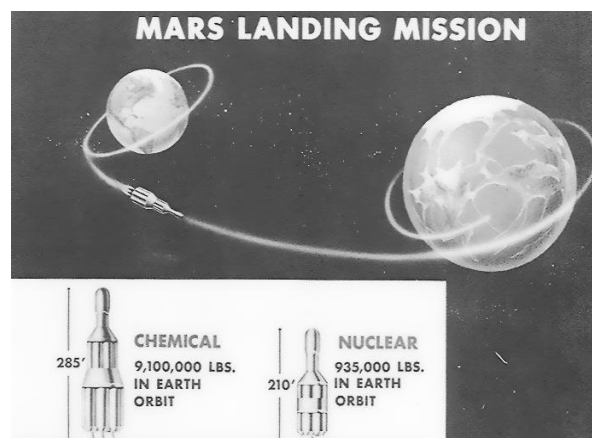

Figure 28. Comparison of Chemical and Nuclear systems for a Mars mission.

	EARTH	MARS
DIAMETER	12,756 km / 7,926 mi	6,792 km / 4,220 mi
AVERAGE DISTANCE FROM SUN	150,000,000 km / 93,000,000 mi	229,000,000 km / 142,000,000 mi
TEMPERATURE RANGE	-88C TO 58C / -126F TO 138F	-140C TO 30C / -285F TO 88F
ATMOSPHERIC COMPOSITION	78% N ₂ , 21% O ₂ , 1% OTHER	96% CO ₂ , <2% Ar, <2% N ₂ , <1% Other
FORCE OF GRAVITY (WEIGHT)	100 LBS ON EARTH	38 lbs ON MARS (62.5% LESS GRAVITY)
DAY LENGTH	24 hrs	24 hrs 40 min
LAND MASS	148.9 MILLION km ²	144.8 MILLION km ² (97% OF EARTH)
PEOPLE	7 BILLION	0

Figure 29. Comparison between Earth and Mars.



Figure 30. Conceptualization of a Mars mission. Source: NASA.

1.10 MARS MISSION CHALLENGES

According to astronaut Buzz Aldrin: "The challenge ahead is epic, but historic. We are on a pathway to homestead the Red Planet."

The idea of a manned journey to Mars inspired science fiction for a century. Since the dawn of the space age, plans have been proposed for how it might be done. In 1989, a plan advanced by President George H. W. Bush to send a manned mission to Mars was shelved when its costs were estimated at more than \$500 billion. In 2010, President Barack Obama called on NASA to set "far-reaching exploration milestones," including sending astronauts to Mars by the mid-2030s.

NASA still has no budget for a manned mission, let alone the technology to land humans there safely and then bring them back. Several commercial spaceflight companies are considering plans to send people to Mars in about a decade.

At the closest points of their orbits, Earth and Mars are 34 million miles apart. It would take a manned spacecraft five to 10 months to reach Mars using chemical rockets propulsion. That is a long time for astronauts to be in interplanetary space, where they would need much tougher protection against space radiation than they do in Earth's orbit.

A trip to Mars would require vast quantities of equipment, food, and fuel. Some investigators have suggested sending supplies separately to allow astronauts to travel in a lighter and faster vessel.

When a manned mission reaches Mars' orbit in good order, landing there safely poses other daunting problems. Mars' atmospheric pressure is less than 1 percent of Earth's, making it difficult to slow a spaceship hurtling toward the surface at an estimated speed of 13,000 miles per hour. Unmanned rovers have cushioned their descents with heat shields, parachutes, inflated balloons and rockets, but current technology is insufficient for landing a much larger manned spacecraft, even if supplies were sent separately. The task at hand involves landing a two-story spacecraft, and then another two-story one with fuel and supplies right next to it.

Space tourist and businessman Dennis Tito endorsed a low-budget, \$128 million plan to send a 50-ish married couple on a 501-day flyby that would zoom past Mars in 2018 and then use the planet's gravity to slingshot the spacecraft back to Earth. The Dutch nonprofit organization "Mars One" envisions to start colonizing Mars within a decade, and has already collected more than 78,000 applications from civilians willing to take a one-way trip to Mars. The group plans to select six teams of four with the necessary "intelligence, resourcefulness, courage, determination, and skill, as well as psychological stability." They would then undergo seven years of training and testing, including time in mock Mars colonies, all to be chronicled in a revenue-yielding Survivor-style television series to make the final cut.

The health risks of long-term exposure to space radiation, reduced gravity, longer days, and extraterrestrial atmospheric conditions pose a challenge. Astronauts are known to experience bone degradation, muscle loss, and swollen optic nerves from spending too much time in zero gravity. A Russian-sponsored experiment called Mars 500, in which six men were confined for 500 days under conditions meant to emulate a Mars mission, showed that Mars travelers could face severe sleep disturbances, lethargy, and depression. To shorten the Mars mission's time to a few weeks rather than years, a high specific-impulse nuclear rocket appears as a necessity, not just a luxury.

Scientists also worry about the Martian surface's ultra-fine dust, which contains highly chlorinated salts called perchlorates that can cause respiratory problems and thyroid damage. And there is a possibility that Mars harbors potentially virulent microbes.

The Mars colonists would need a base large enough to contain comfortable, long-term living quarters and a vast array of life-support systems and supplies. Because of the high wind

velocities on the surface of Mars, it is necessary to build the living enclosures against the sides of hills or underground.

The pressurized, air-tight habitat must be constructed in phases in the way the International Space Station (ISS) was built. A secure, long-term food supply would be crucial. A company is working on 3-D printers that would combine powders and concentrates to create foods that replicate the textures, flavors, and smells of natural foods. Martian farmers could grow food in pressurized greenhouses, using genetically modified crops to compensate for the planet's high radiation and low intensity sunlight. Life on Mars can be envisioned to be stunning, frightening, lonely, cramped, and busy, all at the same time

According to astronaut John Grunsfeld: "Single-planet species do not survive. He is among the researchers, astronauts, and space exploration firms who see establishing an outpost on the Red Planet not just as a scientific challenge, but as essential to mankind's survival. Cosmologist Stephen Hawking shares the thought: "The human race should not have all its eggs in one basket, or on one planet. I believe that we will eventually establish self-sustaining colonies on Mars and other bodies in the solar system. He figures it could happen "within the next 100 years."

Should a nuclear winter, shrinking resources, a growing population, climate change, or a visit by hostile aliens threaten humankind on Earth, a colony on Mars could serve as a Noah's Ark to keep life going.

1.11 MARS MISSION PROPULSION REQUIREMENTS

The true potential of a nuclear rocket is not just for providing power for observation satellites and anti ballistic weapon systems, but for a possible space mission to Mars. The higher specific impulse of the nuclear rocket can reduce the mission time for a Mars mission from about a year for a chemical rocket, to about 2-3 weeks in the case of a nuclear rocket. This may be crucial to avoid the effects of space radiation from solar flares on the astronauts, as well as avoiding the effects of gravity's absence on the muscular bone, and other bodily functions from exposure to space radiation and solar flares in long duration space missions.

Figure 25 compares the chemical and nuclear fission vehicles required to perform a manned Mars exploration mission. Assuming that the space vehicle has been assembled in an Earth orbit, with the components supplied by a space transport vehicle, or reusable rockets, the all-chemical vehicle would have an initial weight in Earth orbit of almost 10 million pounds. The nuclear vehicle weight would be about 1/10 this value, at about 950 thousand pounds. The weight advantage is here clear.

A nuclear rocket would be crucial for the return of the astronauts. The USA NERVA reactor as well as Russian designs used U^{235} as the fuel. New fuels consisting of tricarbide fuel: $(U^{235}, Zr, Nb)C$. The use of Pu^{239} is precluded by United Nations agreements on the use of space. The use of a nuclear rocket cannot be used for landing and return from Mars. Because of its radioactive exhaust, and the added need for surrounding, rather than just shadow shielding of the crew, the landing and return must use chemical rockets, with the nuclear rocket left in orbit around Mars. This is necessary, since the effective dose rate from an unshielded NERVA engine after being fired can be in the range of 10,000 rem/hr, so that the crew cannot stay close to it, should it be landed on Mars. As an illustration, the fission product activity produced from a run lasting 1,000 seconds from a 2,000 MWth nuclear rocket would produce more than 109 Curies (Ci) of

fission products, which is 1/10 what is produced over two year operational period for a typical land-based 3,411 MWth nuclear power plant.

The Orbitech company developed in-situ resource utilization systems to exploit the Martian atmosphere for ground transportation, flight propulsion, and power. Solid CO and C are used as fuels in hybrid rocket propulsion systems. Small-scale solid CO/O₂ hybrid motors, cryogenic solid hybrid rocket engines, vortex combustion ramjets, scramjets, and solid oxygen/liquid hydrogen hybrid engines were pursued.

Because of planetary alignments a window of opportunity for a trip to Mars opens every 26 months, with some windows being better than others. The year 2016 offers a good window. NASA's Johnson Space Center estimates the cost of a mission including 3 trips to Mars at \$50 billion. A scaled down approach could be done for 20-30 billion in 2000 dollars.

On Mars, nuclear power would be needed. Because of dust storms and high wind speeds, a Mars colony would have to be sheltered underground, and need a reliable power supply for heat, transportation, food production, water supply, communications and other life supporting measures. The environment on Mars is very harsh. Temperatures average at below 273 K, and are at 148 K at the Polar Regions. The climate is dry and hostile, threatening the astronauts at every turn.

Providing energy, particularly heating for the astronauts cannot depend on solar energy or on radioisotope generators, and needs a nuclear reactor source. A mission composed of 4 astronauts would need a power supply of about 140 kWe. Most radioisotope generators have used plutonium²³⁸, and assuming a dynamic conversion system's efficiency of 30 percent, the thermal energy needed for the astronauts is $140 \times (100 / 30) = 466.66$ kWth. One needs about 1.8 kg of Pu²³⁸ per kWth produced. Thus one needs: $1.8 \times 466.66 = 840$ kgs of Pu²³⁸. This amount is beyond any possible existing supply, and suggests that such a mission, for reliability reasons, would require at least two nuclear reactors producing a thermal power of 0.5 MWth each, for a total of 1 MWth of power. During the Martian day, three solar power systems at 10 kWe each may supplement their needs.

It will take at least a decade of research and development, with an expense of at least \$50 billion to prepare for a Mars mission. NASA has been lately trying a strategy of "faster, cheaper, better," in its exploration of Mars, leading to about a 2 out of 3 as a success rate. With manned space mission, a higher degree of reliability will be needed.

1.12 EXTERNAL PULSED PLASMA PROPULSION

INTRODUCTION

This is a nuclear propulsion concept generating its thrust with plasma waves generated from a series of miniature supercritical fission or fusion pulses. The intense plasma wave energy transfers its momentum into vehicle acceleration that can be withstood by the structure of the vehicle and its crew. Very high specific impulses and thrust to weight ratios can be obtained by this approach, which other technologies cannot obtain. Their appeal also stems from their low costs and reusability. They offer fast interplanetary transit times, safety and reliability, and do not require major technological breakthroughs. This could be the only realistic approach available with present day technology for a Mars mission in the twenty first century.

THE ORION PROJECT

The USA Air Force pursued this project on a classified basis between 1958 and 1965. The proposed space vehicles would be 10-30 meters in diameter, since the performance tended to increase proportionally to the diameter of the lower pusher plate. This is due to the higher specific yields or burnup fractions which increase with the size of the pulse units, as well as the wider solid angle intercepting the plasma from a larger plate, at the minimum standoff distance between the plate and the point of detonation. This distance is determined by material strength and materials ablation considerations. The ablative material pusher plate would absorb the impact and thermal shocks.

The effort was not continued for political reasons. However it has been established that a space vehicle with high thrusts of 1-10 g accelerations, high specific impulse in the range of 10,000 secs can be built.

The yield of the pulse units were in the range of 0.01 kT, and the repetition rate was in the range of 0.1-1 pulses per second. The standoff distance ranged from 100-1,000 feet.

GOVERNING RELATIONS

Consider the masses of the pulse unit device and the payload as:

$$\begin{array}{ll} \text{Pulse unit device mass} & = m_d, \\ \text{Payload mass} & = m_p, \end{array}$$

As well as their respective velocities as:

$$\begin{array}{ll} \text{Pulse unit device velocity} & = v_d, \\ \text{Payload velocity} & = v_p. \end{array}$$

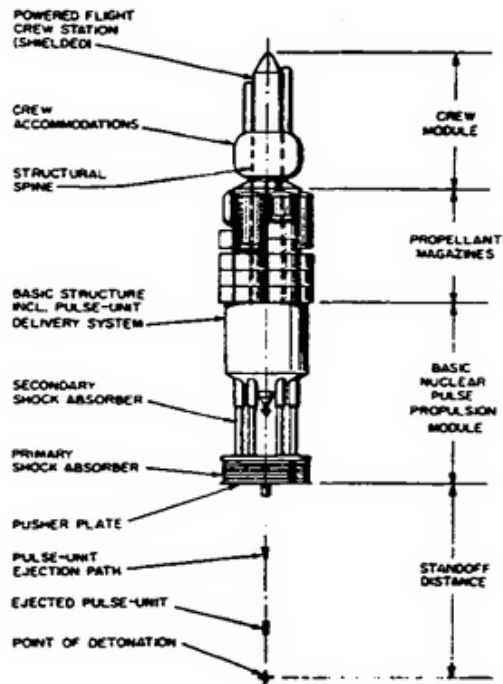

Figure 31. An External Pulsed Plasma Propulsion, EPPP Space Vehicle.

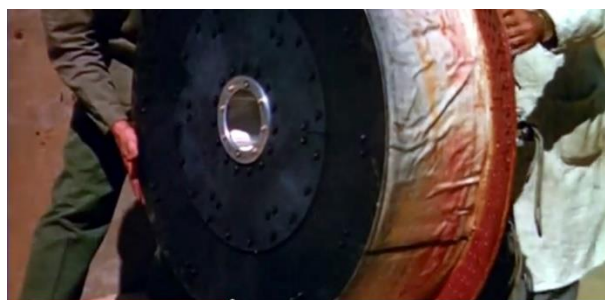
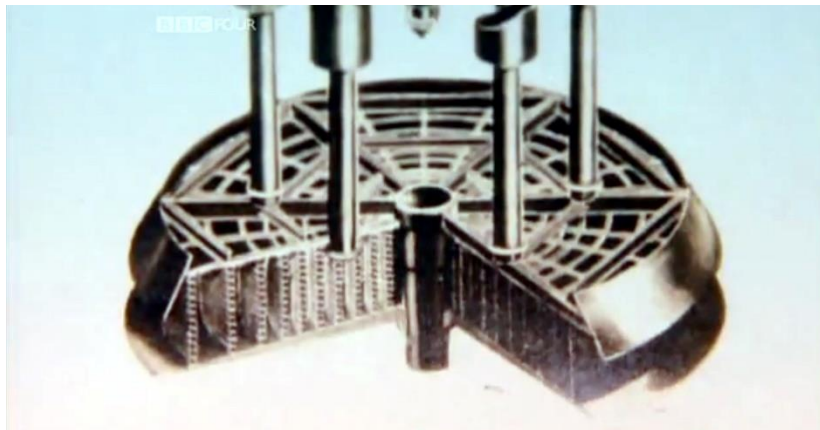

Figure 32. Orion pusher plate design. Source: GA.

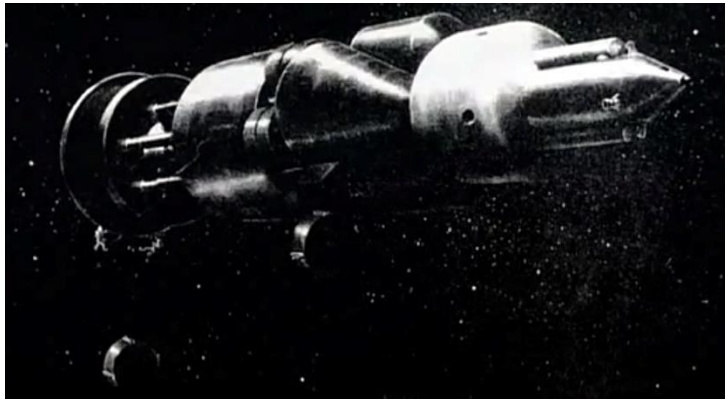
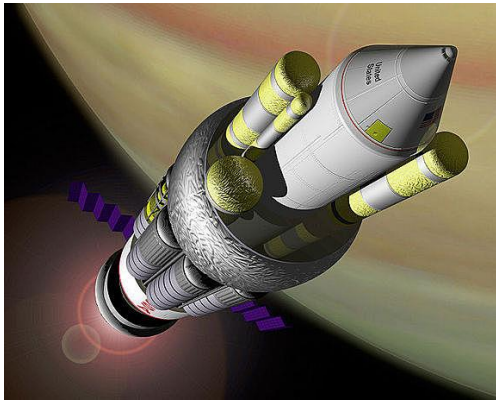

Figure 33. Orion rocket in space.





Figure 34. Testing the Orion concept with chemical explosives.

Assuming that all the energy of the pulse device, E is released in the form of kinetic energy, applying conservation of energy, then:

$$E = \frac{1}{2} m_d v_d^2 \quad (14)$$

The fraction of solid angle intercepted by the pusher plate in spherical coordinates is:

$$\begin{aligned} f &= \frac{\int_0^\theta dV}{V} = \frac{\int_0^R \int_0^{2\pi} \int_0^\theta r^2 \sin \theta dr d\theta d\phi}{\frac{4\pi R^3}{3}} \\ &= \frac{\int_0^R r^2 dr \int_0^{2\pi} d\phi \int_0^\theta \sin \theta d\theta}{\frac{4\pi R^3}{3}} \\ &= \frac{1}{2} (1 - \cos \theta) \end{aligned} \quad (15)$$

The fraction of energy transferred to the pusher plate becomes:

$$E' = \frac{1}{2} f m_d v_d^2 = \frac{1}{4} (1 - \cos \theta) m_d v_d^2 \quad (14)'$$

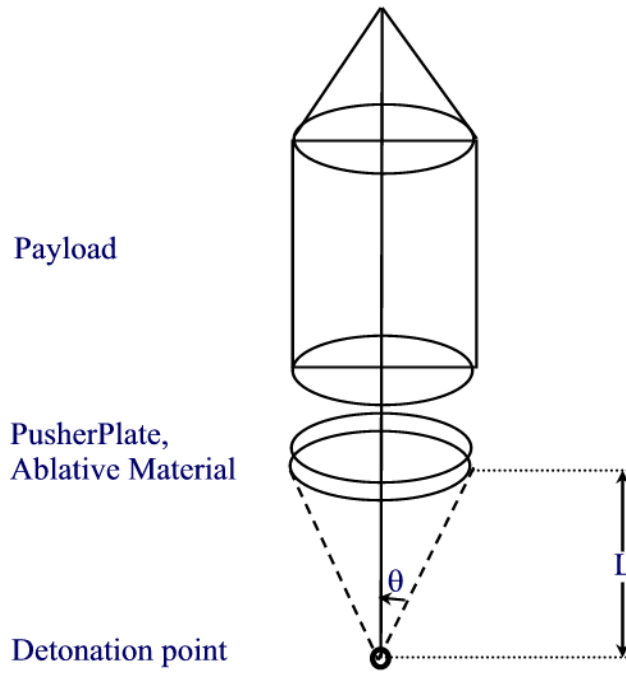

Figure 35. Geometry for the External Pulsed Plasma Propulsion, EPPP Rocket.

Applying conservation of momentum yields:

$$m_p v_p = m_d v_d, \quad (15)$$

from which:

$$v_d = \frac{m_p}{m_d} v_p$$

Eliminating v_d from Eqn. 14, yields:

$$fE = \frac{1}{2} m_d \left(\frac{m_p}{m_d} v_p \right)^2 = \frac{1}{2} \frac{m_p^2}{m_d} v_p^2 \quad (16)$$

One can thus deduce the payload velocity as:

$$v_p = \frac{1}{m_p} (2Ef m_d)^{\frac{1}{2}} = \frac{1}{m_p} [E(1 - \cos\theta)m_d]^{\frac{1}{2}} \quad (17)$$

and the device's particle velocity as:

$$v_d = \frac{1}{m_d} (2Efm_d)^{\frac{1}{2}} = \left[\frac{E(1 - \cos\theta)}{m_d} \right]^{\frac{1}{2}} \quad (18)$$

Considering that the device's plasma collides with the pusher with a velocity v_d , and is reflected with a velocity in the opposite direction ($-e.v_d$), where e is the collision elastic parameter, the change in momentum will be:

$$d(mv_d) = m[v_d - (-ev_d)] = mv_d(1 + e) \quad (19)$$

The specific impulse in this situation can be written as:

$$I_s = \frac{\int F dt}{mg_0} = \frac{\int \frac{d}{dt}(mv_d) dt}{mg_0} = \frac{\int d(mv_d)}{mg_0} \quad (20)$$

Substituting from Eqn. 19 into Eqn. 20 we get:

$$I_s = \frac{v_d(1 + e)}{g_0} \quad (21)$$

Substituting for v_d from Eqn. 18, we get:

$$I_s = \frac{(1 + e)}{g_0} \left[(1 - \cos\theta) \frac{E}{m_d} \right]^{1/2} \quad (22)$$

For an elastic collision, where the expanding plasma loses all its momentum to the pusher plate, $e = 1$, and:

$$I_s = \frac{2}{g_0} \left[(1 - \cos\theta) \frac{E}{m_d} \right]^{1/2} \quad (22)'$$

This equation shows that the specific impulse will be proportional to the specific yield of the device (E / m_d), and the subtended solid angle. The use of a fusion component would maximize this ratio. Devices where the energy is collimated through this solid angle, where the pusher plate would subtend most of the released energy, would be more effective than the spherically symmetric ones.

DIRECTED ENERGY PULSE UNITS

It is possible to direct the energy of a nuclear device through a chosen solid angle instead of distributing all its energy into a 4π solid angle using asymmetric burns. The energy from a nuclear device is channeled through a radiation case containing a channel filler to generate a plasma that transfers the energy to a propellant plate.

Initially a low Z material was used in the Orion project. It was replaced by a high Z element. This results in a dense plasma (high Z case) at a relatively low velocity at a wide angle, instead of directing a lower density plasma (low Z case) at a higher velocity and a narrower angle as used in the Strategic Defense Initiative (SDI) or Star Wars Project directed energy project designated as the Casaba-Howitzer.

A schematic of a pulse unit for a 10 meters in diameter Orion vehicle is shown in Fig. 28. It would yield about 1 kT of energy, and weigh 311 lbs. About 2,000 to 3,000 charges would be needed for a return trip to Mars. The initial burst of energy is confined by the radiation case and channeled toward the propellant slab.

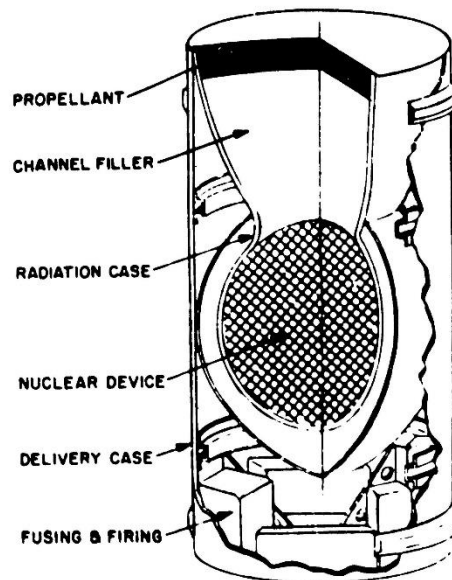

Figure 36. Design of a directed energy pulse unit with a heavy element propellant pusher plate. Propellant: Tungsten, Channel Filler: Beryllium oxide, Radiation case: Uranium.

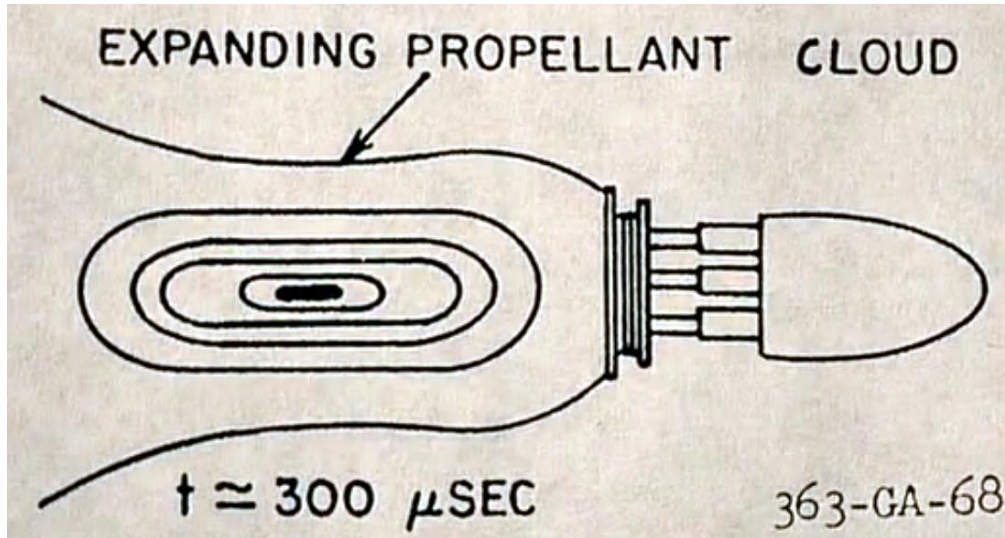

Figure 37. Expanding propellant cloud in the Orion concept. Source: General atomics.

FREE EXPANSION OF A PLASMA IN VACUUM

The free expansion of a gas in a vacuum results in the propellant disc expanding in an asymmetric expansion fashion. Since the plasma fluid would have a larger pressure gradient in the axial direction of the disc, it will expand into the shape of a cylinder.

Interestingly, an inverse process would also occur: The free expansion of a cylinder would result in a disc shape. Under asymmetric free expansion a pancake shaped plasma would expand into the shape of a melon, and a melon shaped plasma would expand into the shape of a pancake.

The free expansion yields an expanded diameter to length ratio inversely proportional to the square root of the initial diameter to length ratio.

$$\left(\frac{D}{L}\right)_1 \propto \frac{1}{\sqrt{\left(\frac{D}{L}\right)_0}} \quad (23)$$

For instance, starting with a plate with an initial diameter to length ratio:

$$\left(\frac{D}{L}\right)_0 = 4,$$

would result in a cylinder of diameter to length ratio of:

$$\left(\frac{D}{L}\right)_1 = \frac{1}{\sqrt{\left(\frac{D}{L}\right)_0}} = \frac{1}{\sqrt{4}} = \frac{1}{2}$$

Thus starting from a flat plate can yield through asymmetric free expansion a plasma jet that is collimated within about 20 degrees.

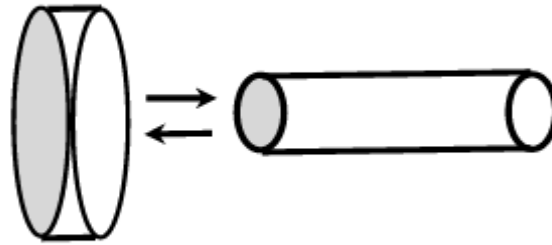

Figure 38. Free asymmetrical expansion of pancake into cigar shaped plasma, and the inversion of a cigar into a pancake shape.

VARIABLE DENSITY PUSHER PLATE

A further refinement in time shaping the pulse delivered to the Orion vehicle shock absorber can be achieved by controlling the distribution of density of the expanding plate.

The load on the pusher is governed by the local density of the propellant plasma multiplied by the square of its velocity.

A variable density in the plate can yield a softer ride and more effective horse power. In this case where an initial lower density is used in the back of the plate and a higher density in its front, or vice versa, the pressure pulse can be spread out over time or contracted, mitigating the effect of the shock to the space ship. This approach to pulse shaping is crucial for a viable propulsion system, instead of just having a rapid rise in pressure followed by an exponential decay.

PRACTICAL CONSIDERATIONS

As initially considered in the Orion project, the vehicle would be launched from the Earth's surface. The release of radioactivity in the atmosphere was an unacceptable alternative at the time, and still remains so. However, if the components can be launched with a transport vehicle to low Earth orbit and assembled there, these objections disappear. The space environment is already extremely harsh in terms of radiation. It has more background radiation in the form of gamma rays than the small pulse units would produce. In a matter of 24 Earth hours, the resulting ionized mass would dissipate in the background space plasma density. The exhaust particles velocities

would exceed the Earth's escape velocity and even the solar escape velocity, resulting in no residue or permanent contamination above the level caused by the natural radiation from the sun.

This technology is immediately available for space missions. There is no guarantee that other technologies such as fusion propulsion, matter/antimatter and beamed-energy sails that are under study will be available during the first half of the twenty-first century. Fusion must await the demonstration of a system possessing sufficient energy gains for commercial and space applications. Matter/antimatter has low propulsion efficiency and a prohibitive cost of the possible production and storage methods. Beamed energy would require tremendous investments in ground and space based infrastructure.

The need for high power densities for space missions favors nuclear energy sources. Solid core nuclear thermal, gas core, and electrical nuclear propulsion systems have problems with the constraint of the need of containment of a heated gas, which restricts its specific impulse values. External pulse systems possess higher temperature limits and lower inert masses and circumvent that limitation.

Several methods of external momentum coupling have been investigated other than the standard pusher plate. These include a combined magnetic field and pusher plate, a rotating cable pusher, and a large lightweight sail.

Because the reaction is external to the material walls of the vehicle, the system's operation is independent of the reaction rate, pressure temperature and the fuel characteristics. The physics of fission in a vacuum are simple where a shell of ionized gas with extremely large radial velocities is produced. It is also recognized that common materials can withstand an intense nuclear damage environment over short intervals of time in the nanoseconds range. The acceleration of the ship is only limited by human and equipment tolerances. Imparting high thrust for short periods of time results in fast and efficient trajectories. Research emphasizes low ablation pusher plate designs, low energy pulse unit yields, and dedicated space operation out of the Earth's atmosphere.

The overall advantage is that this approach can yield space vehicle for a Mars mission of duration of just 1-3 months. This should be compared to the mission time of about 25 months with chemical or other propulsion technologies. The latter technologies favor Hohmann type transfers into very slow heliocentric orbital trajectories; which narrows the available trajectories for return and necessitates long stays on the Mars surface waiting for the occurrence of favorable return windows. This stay would be in an extremely hostile environment with 560 days surface stays and 170-200 days transit times. It would also provide more flexible return windows and eliminate the need for long stay times in the vicinity of Mars, where the astronauts' bodies would be ravaged by the effects of a long period of weightlessness and high space radiation, in addition to the lurking deadly danger of unforecast solar flares.

Short duration missions on Mars provide by External Plasma Pulse Propulsion would also be associated with lower overall mission costs. Longer missions translate into a need for larger payloads and expandables that need to be launched into space at high cost.

The specific impulse of nuclear thermal systems is in the range of 900 sec, which is about twice those of chemical propulsion systems in the range of 450 sec. The main advantage here is the reduction of the vehicle mass in low Earth orbit, thus reducing the number of heavy lift vehicle launches.

External Pulse Plasma Propulsion is distinguished by specific impulses in the range of 5,000-10,000 secs. Even higher specific impulses of 100,000 secs can be achieved with larger

vehicles, and more energetic detonations using fission/fusion and fusion sources. These can open up the whole solar system for human exploration and colonization.

1.13 SPACE-X INTERPLANETARY VEHICLE

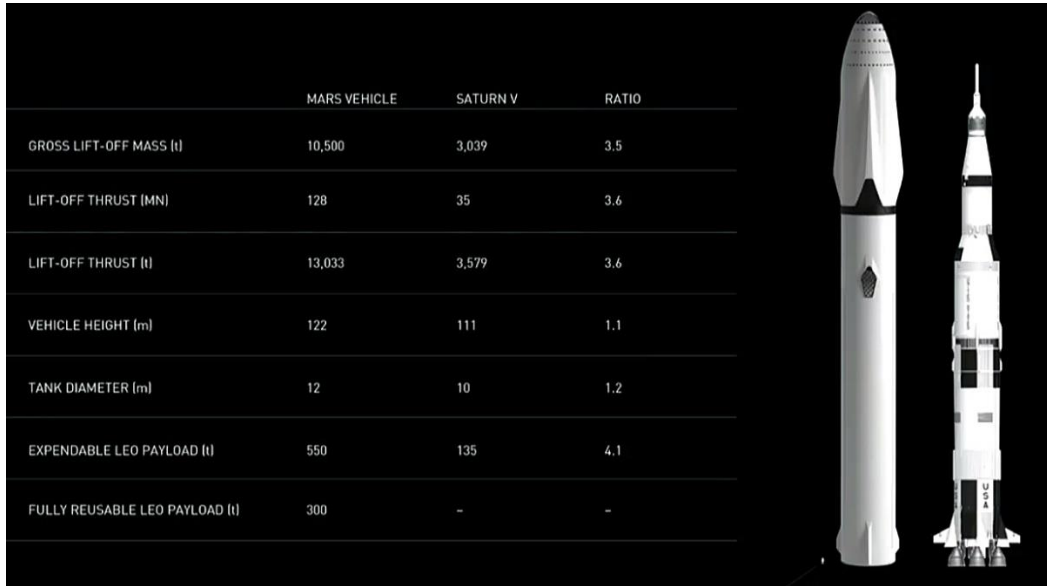

Figure 39. Comparison of NASA Saturn V Apollo missions to the moon rocket and Space X Mars Interplanetary Transport System (ITS). Source: Space X.

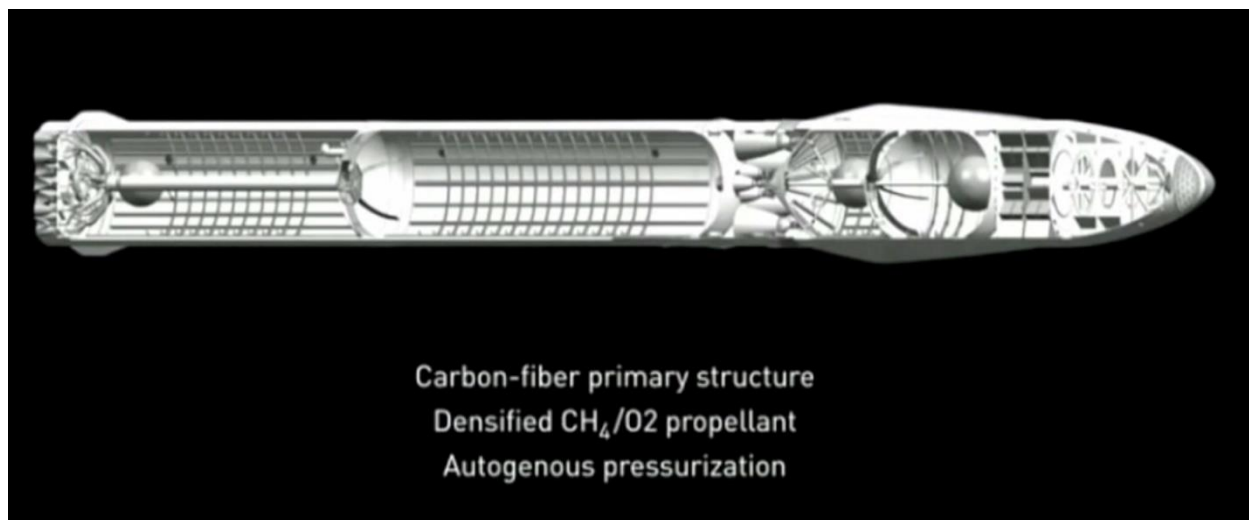

Figure 40. Mars ship cross section. Source: Space X.

Visionary Elon Musk plans to get 1 million people to Mars. At the International Astronautical Congress in Guadalajara, Mexico on September 27, 2016 the SpaceX founder and CEO unveiled the company's Interplanetary Transport System (ITS), which would combine the

most powerful rocket ever built with a spaceship designed to carry at least 100 people to the Red Planet per flight [15].

The reusable ITS would help humanity establish a permanent, self-sustaining colony on Mars within the next century.

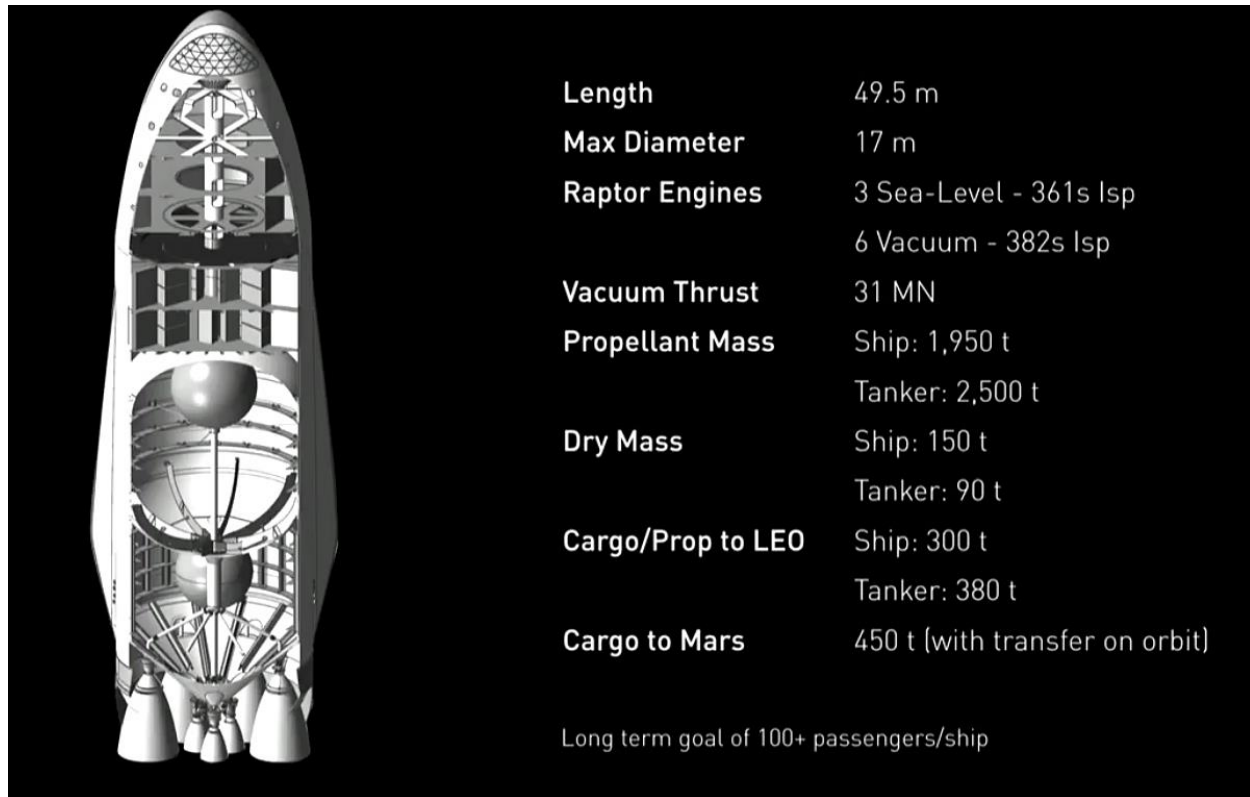

Figure 41. Mars Transport vehicle. Source: Space X.

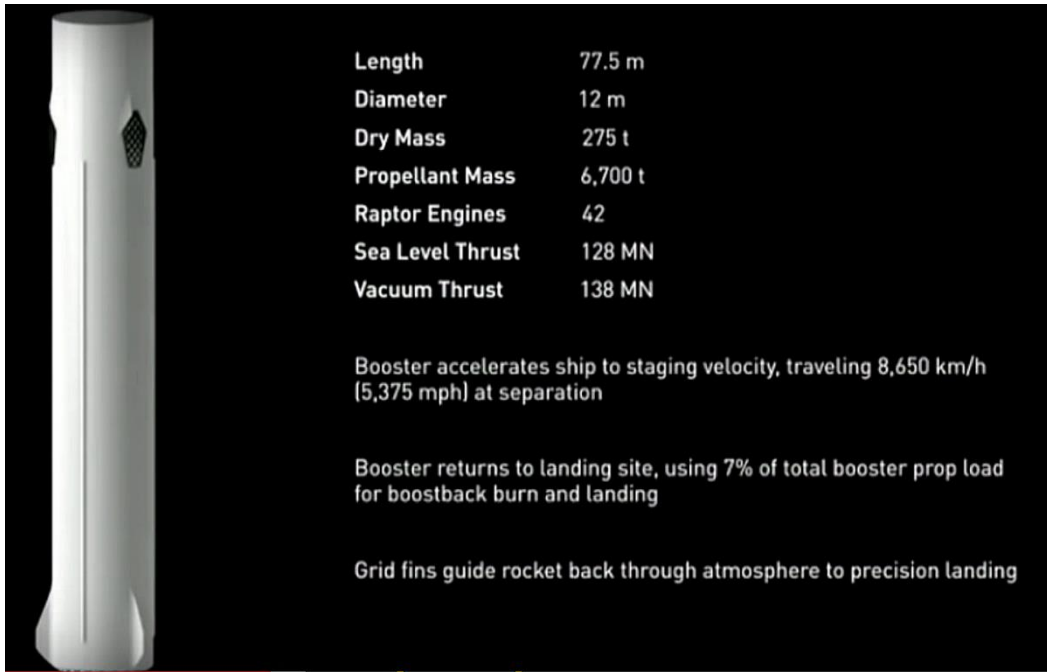

Figure 42. Reusable booster specifications. Source: Space X.



Figure 43. Raptor engine design. Specific impulse of 334-382 is predicted. Source: Space X.

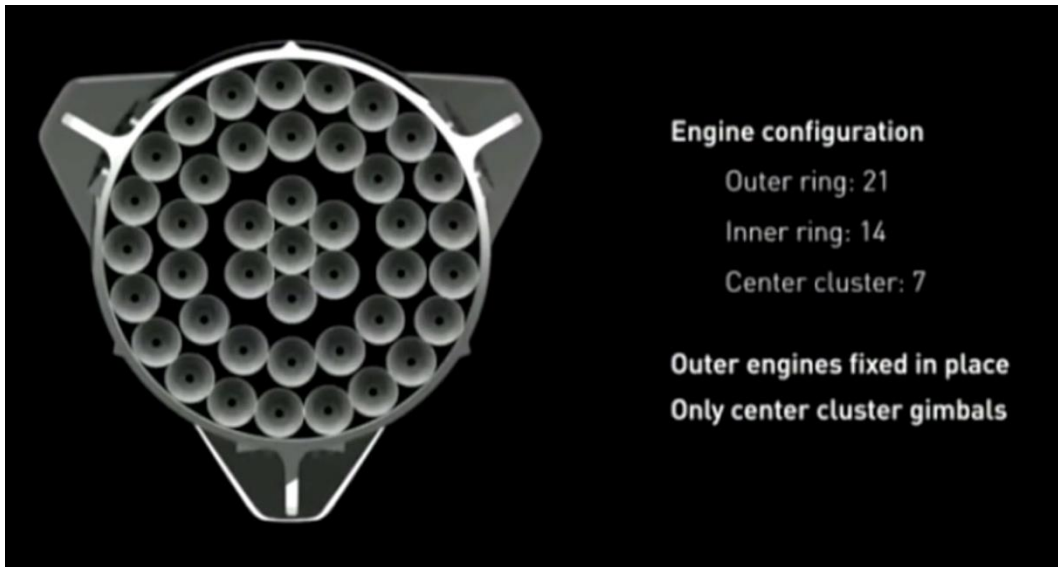

Figure 44. Raptor engines cluster. Source: Space X.

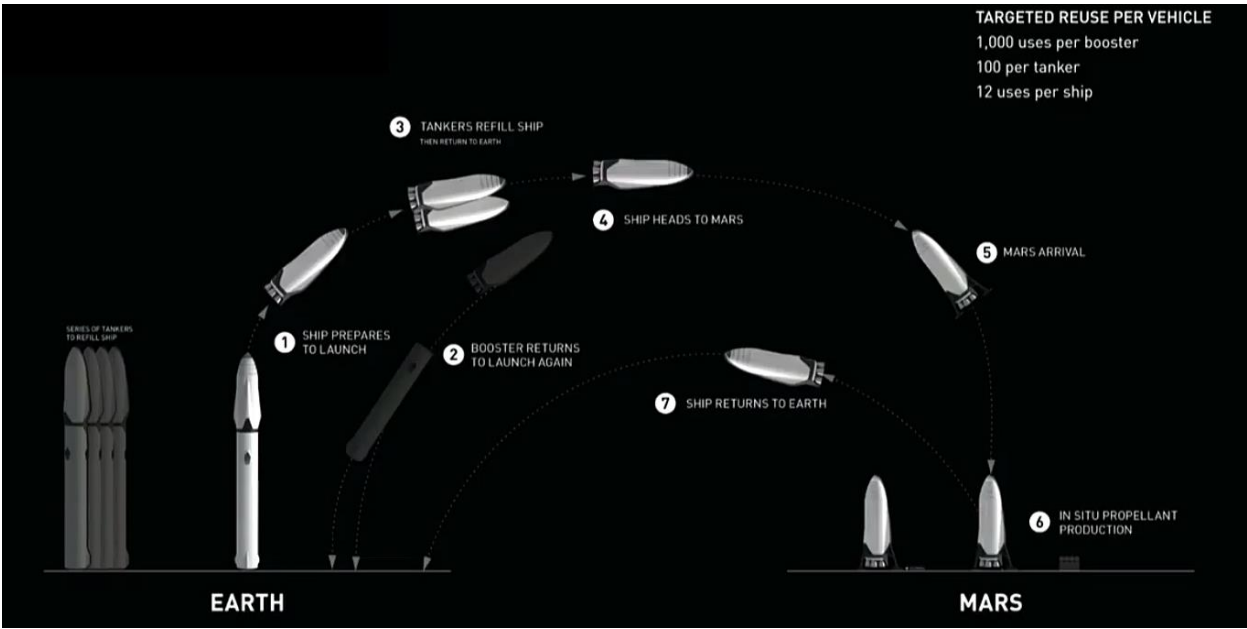

Figure 45. Space reusable vehicle. Source: Space X.

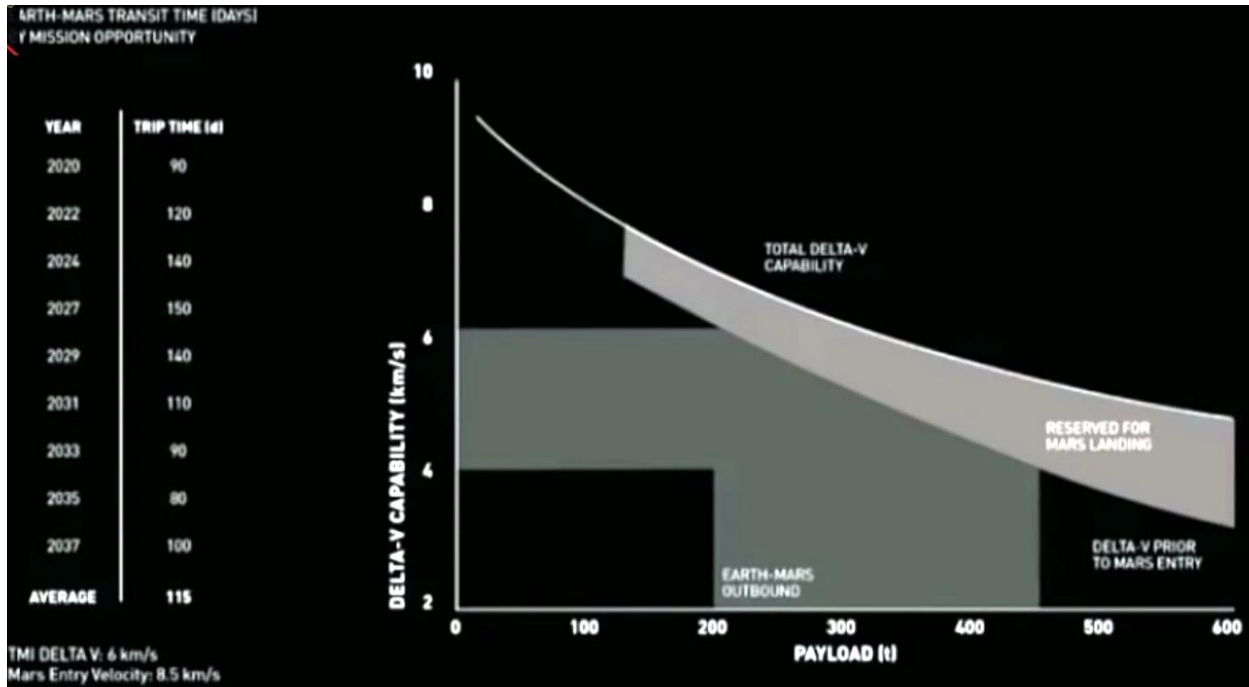

Figure 46. Transit time for a Mars mission. Source: Space X.

The ITS rocket is a scaled-up version of the first stage of SpaceX's Falcon 9 booster. The 254-foot-tall or 77.5 meters ITS booster will feature 42 Raptor engines, whereas the Falcon 9 is powered by nine Merlin engines. When combined with its crewed spaceship, the ITS will stand a full 400 feet or 122 m high. That would make it taller even than NASA's Saturn V Apollo missions moon rocket.

The Raptor engine is about the same size as the Merlin engine but three times more powerful. The reusable ITS is capable of lifting 300 tons to Low Earth Orbit (LEO) twice more the lift capability of NASA's Saturn V could lift. An expendable variant could launch about 550 tons to LEO.

The spaceship is 162 feet or 49.5 m tall and 56 feet or 17 m wide and has nine Raptors of its own. The booster will launch the spaceship to Earth orbit, then return to make a soft landing at its launch site, which is currently envisioned to be Launch Pad 39A at NASA's Kennedy Space Center in Florida.

The spaceship will lift off with little if any fuel on board, to maximize the payload — people, cargo or a combination of both that the craft is able to carry to orbit. An ITS booster will launch again, topped with a tanker, and rendezvous with the orbiting spaceship to fill its tank.

When the Earth and Mars align favorably for interplanetary missions just once every 26 months, the spaceship portion of the ITS will turn its engines on and blast from Earth orbit toward Mars.

The spaceship is capable of transporting 100 - 200 people. It will feature movie theaters, lecture halls and a restaurant, giving the Red Planet pioneers a far different experience than that enjoyed by NASA's Apollo astronauts, who were crammed into a tiny capsule on their way to the moon [15].

The Raptor engines will allow the ship to make the trip in about 80 days, depending on exactly where Earth and Mars are at the time. It takes six to nine months for spacecraft to reach Mars using currently available technology. Eventually the travel time to just 30 days or so, using a nuclear high specific impulse rocket.

When the ITS is up and running, 1,000 or more of the ships will zoom off to Mars every 26 months. The fleet would land on Mars using supersonic retro-propulsion, slowing down enough to touch down softly by firing onboard thrusters rather than relying on parachutes. The upcoming "Red Dragon" mission, aims to launch SpaceX's uncrewed Dragon capsule toward Mars in May 2018 [15].

SpaceX plans to build a solar-powered factory on Mars that will use the carbon dioxide and water ice in the planet's air and soil, respectively, to generate methane and oxygen — the propellant used by the Raptor engine. The ITS spaceships will be refueled on Mars and will launch back to Earth from there, meaning prospective colonists do not have to stay on the Red Planet forever if they do not want to. Getting off Mars does not require a big rocket, because it has a weaker gravitational pull. Each ITS spaceship will be able to fly at least a dozen times, and each booster should see even more action. This reusability is the key component of SpaceX's plan, and should be the chief driver in bringing the price of a Mars trip which Elon Musk said would cost about \$10 billion per person using today's technology down to reasonable levels. The architecture allows for a cost per ticket of less than \$200,000 and ultimately below \$100,000 [15].

The ITS could enable human exploration of Jupiter's ocean harboring moon Europa or allowing cargo to get from New York to Tokyo in just 25 minutes.

"The objective is to become a spacefaring civilization and a multiplanet species," the billionaire entrepreneur said, adding that doing so will make humanity far less susceptible to extinction [15].

1.14 DAEDALUS SPACE SHIP STUDY

An interstellar space ship study was conducted over the period 1973-1978 by the British Interplanetary Society, designated as the Daedalus Project. A target was used as the Barnard's Star system, a red dwarf at a distance of 5.91 light years from the sun that was sought at the time to be possibly orbited by planets. To reach its destination within 50 years, the ship had to cruise at 12 percent of the speed of light at 36,000 km/sec.

A fusion propulsion system was selected using the D-He³ fusion reaction producing H and He⁴ charged particles that could be diverted using magnetic fields was selected rather than a fission system like the Orion project. The He³ isotope would have to be bred from lithium into tritium that would decay into He³ on Earth, or alternatively mined from the surface of the moon whose dust is rich in He³ deposited by the solar wind.

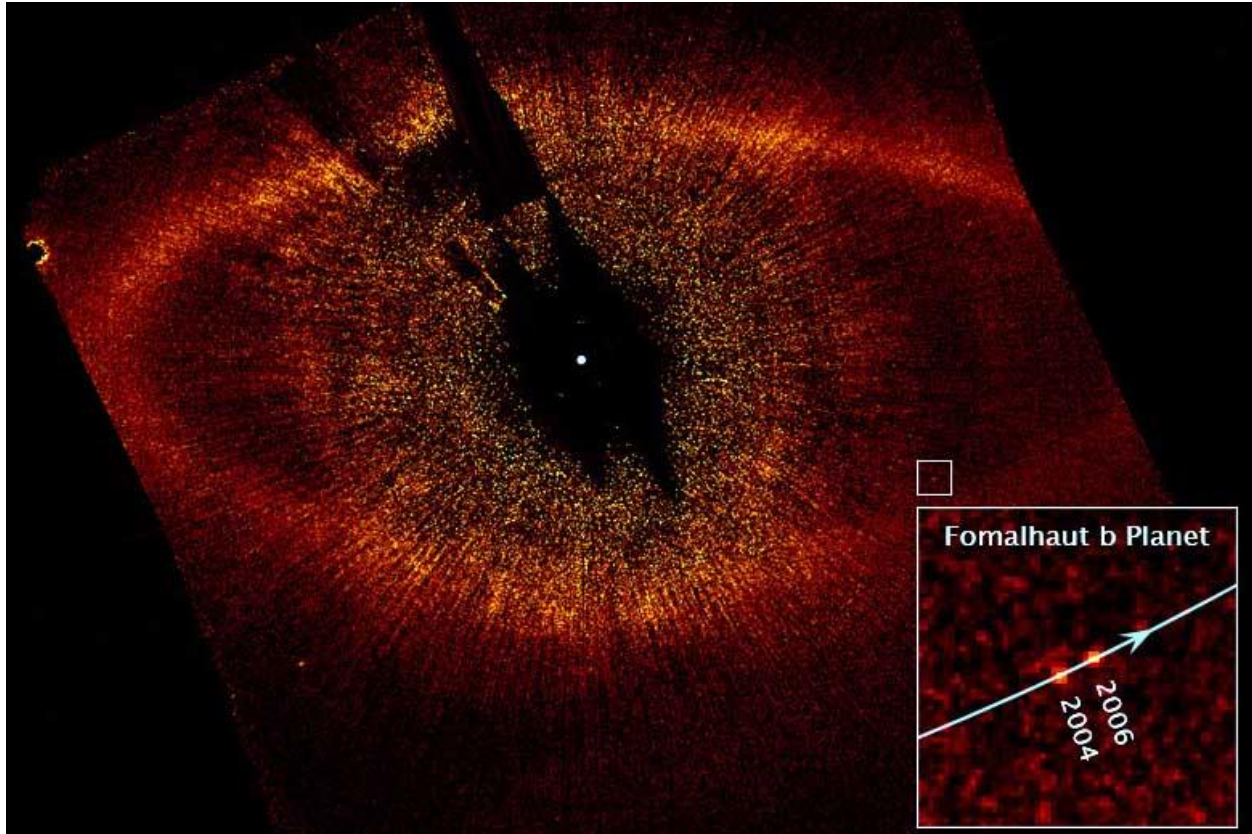

Figure 48. The Hubble Space Telescope was used to take the first visible-light snapshot of a planet orbiting another star. The images show the planet, named Fomalhaut b, as a tiny point source of light orbiting the nearby, bright southern star Fomalhaut, located 25 light-years away in the constellation Piscis Australis. A large debris disk about 21.5 billion miles across surrounds the star. Fomalhaut b is orbiting 1.8 billion miles inside the disk's sharp inner edge. Photo: NASA.

In an inertial confinement fusion system, fusion pellets would be irradiated by electron or laser beams. The charged particles products would be channeled by a magnetic field as a hot plasma out of a nozzle to provide the required thrust. A repetition rate of 250 pellets/second and the use of a two stage system would attain the cruising speed within a 4 years acceleration period.

The space ship would be assembled in Earth orbit with a weight of 54,000 tons of fuel and a 500 tons scientific payload. The first stage would be fired over two years to attain 7.1 percent of the speed of light then jettisoned. The second stage would fire for the next 1.8 years for a 46 years cruise to the Barnard's Star. About 18 probes powered by ion drives would be used to investigate the star and its planets. A 50 ton, 7 mm thick disc of high strength beryllium metal would be used to shield the payload bay from collisions with space dust and meteoroids on the flight. An artificially generated cloud of particles 200 km ahead of the vehicle would disperse larger particles as it reached the planetary system of the target star.

It would take 12 years for the radio signals from the probe to reach Earth. Accordingly, the probe must be self autonomous using artificial intelligence controls. The first step for such a mission in the 21st century has been taken by NASA in its Deep Space 1 probe.

1.15 TRIP TO ALPHA CENTAURI

Scientists using the European High Accuracy Radial velocity Planet Searcher (HARPS) telescope detected in October 2012 the gravitational tug of an Earth-size planet dubbed Alpha Centauri Bb, in the Alpha Centauri B star system. Apart from Proxima Centauri, a small star located 4.2 light-years away and thought to be gravitationally bound to the Alpha Centauri binary, Alpha Centauri is the closest star system and a ripe target for a future interstellar probe.



Figure 49. Milky Way Galaxy.

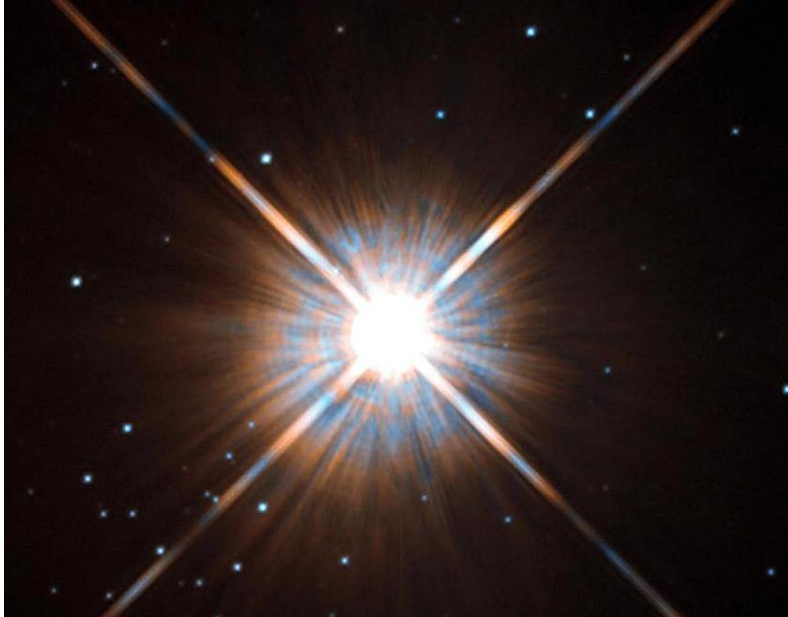

Figure 50. Proxima Centauri. Source: ESA/Hubble.

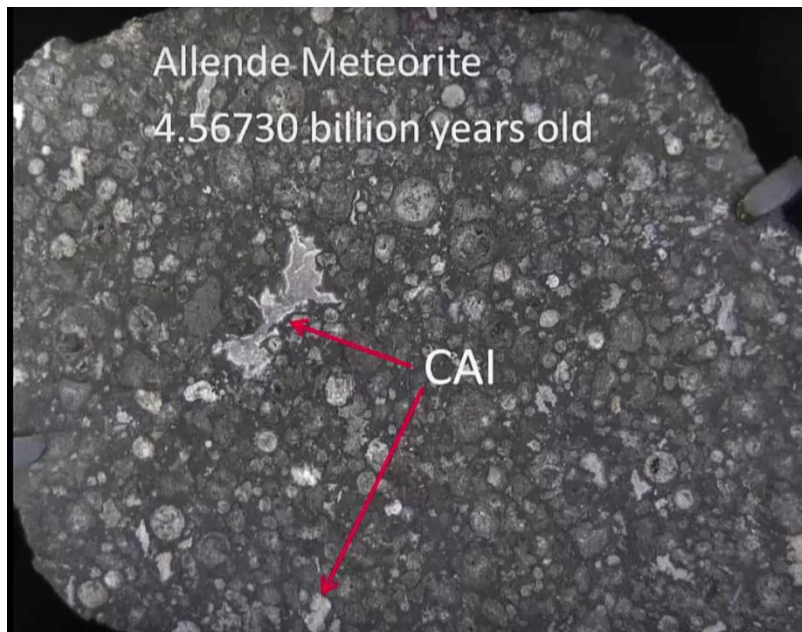

Figure 51. Allende meteorite.

The new planet was found using the Doppler or wobble, technique to find exoplanets. It measures shifts in a star's spectrum that indicate how fast a star is approaching or receding from the Earth's radial velocity. A planet orbiting the star would exert a small tug on the star that would slightly change the star's radial velocity in a regular pattern. The HARPS team has found more than 150 exoplanets using this method. The tug from the planet around Alpha Centauri B was so

small that it approached the limits of the HARPS spectrograph's sensitivity, and it took them three years to confirm the discovery.

Alpha Centauri lies 4.3 light-years or some 25.4 trillion miles from Earth in the constellation of Centaurus. The collective light of the Alpha Centauri system, situated well south of the celestial equator so it is not visible at latitudes north of Florida, is the third brightest star in the sky. The alpha Centaury system has three different types of stars. A telescope reveals a pair of stars: Alpha Centauri A is a yellow star, slightly larger and brighter than the sun, while Alpha Centauri B is red, and fainter than the sun. The stars circle around a common center of gravity every 80 years. A third member of the system, a very dim red dwarf known as Proxima, lies much farther away and is actually the closest known star to the sun.

Alpha Centauri has often been cited as a logical first destination for a space probe should humanity ever venture out among the stars. It has fired the imagination of such science fiction writers as Isaac Asimov, Arthur C. Clarke, and Buzz Aldrin, who wrote *Encounter with Tibor* with John Barnes; on screen Alpha Centauri has harbored such worlds as *Avatar's* Pandora and *Transformers' Cybertron*, and was the intended destination of the *Jupiter 2* before that space-craft was *Lost in Space*.

The New Horizons mission, which achieved the fastest launch velocity of any spacecraft, is due to pass Pluto in 2015 after a 9.5-year journey; at its speed, it would take about 70,000 years to reach Alpha Centauri. Astronauts have not ventured beyond low-Earth orbit in 40 years, and NASA missions have faced the axe in this climate of fiscal austerity. Higher-end NASA missions like New Horizons and the larger and even more expensive Curiosity Mars Science Laboratory are relatively few as the space agency's watchwords have become smaller, leaner, cheaper. It was only in the 1990's that the first planets orbiting other stars were found, and astronomers have confirmed by 2012 more than 800 exoplanets, with several thousand planetary candidates still being analyzed. Most of the Kepler project's discoveries are hundreds if not thousands of light years away; PH1 is about 5,000 light years from Earth.

If astronomers were to find a smallish world in the habitable zone of Alpha Centauri B or A, or another nearby star, it would present a tempting target, at first for study and perhaps someday for visitation. It could spur the development of telescopes to seek and study planets. If we were to send missions to Alpha Centauri, the first would undoubtedly be an unmanned probe. The obstacles are daunting. Even if a spacecraft were to fly at 5 percent of the speed of light, which is far beyond our current capabilities, it would take a human lifetime over 85 years simply to reach Alpha Centauri.

Nonetheless, some scientists are already focused on how to journey to the stars. The 100 Year Starship study, a joint project between NASA and DARPA, is funding efforts to work towards developing interstellar travel within the next 100 years, and laying the groundwork for an organization that can carry forth that vision. A foundation led by former astronaut Mae Jemison was selected to lead the effort.

Whether such a goal is feasible is an open question. Such an undertaking faces huge practical obstacles, financial and otherwise. But just as human spaceflight has developed technologies that can be used in terrestrial endeavors and inspired generations of engineers, so could a project to literally reach for the stars. We would have to develop an effective energy source to power a starship, and that itself has the potential to both pay for itself and transform society.

Icarus Interstellar Inc. considers the “Icarus” project to realize the possibility of sending an unmanned probe to another star system within the next century. Interstellar distances are vast, so it is desirable to look for new worlds to explore that are located in our cosmic backyard.

A compelling reason is the idea of colonization of other solar systems, which would not only be a natural extension of mankind's compulsion to explore and settle new lands, but also serve as an excellent hedge for the very survival of our species should Earth experience some catastrophic event leaving it uninhabitable such as volcanic eruptions, earthquakes, tsunamis or comet and asteroid collisions that can lead to mass extinctions.

One of the design requirements for an interstellar vehicle is that it must arrive at its destination within 100 years from launch and it becomes a question of how far, realistically, could a starship go within that tight timeframe. The actual target will probably have to be significantly closer than 15 light-years from Earth. Within 15 light-years of the sun there are approximately 56 stars, in 38 separate stellar systems. It would be wonderful if neighboring stars harbored Earth-sized exoplanets.

When scientists would be able to image an Earth-like extra-solar planet, they would be able to determine the planet's atmosphere and surface temperature from its spectrum, and know whether it might be able to sustain Earth-like life and/or could be suitable for human habitation.

The discovered planet Alpha Centauri Bb orbit is ten-times closer to its star as Mercury is to the sun. It would be a rocky, molten world. Alpha Centauri Bb orbits well inside the nearest edge of the star's habitable zone, which is the region where liquid water can exist on the surface.

The quest for life on other planets should be the core mission of our major space agencies for the 21st century and beyond. Such a vision would galvanize public support behind them. Detecting small exoplanets at larger orbital distances from the star cannot be done using the radial velocity detection technique since Earth-mass worlds orbiting further away will have less of a gravitational impact on the host star, thereby causing it to wobble less. These very sensitive radial velocity measurements are incapable of detecting Earth-mass planets in the Alpha Centauri B habitable zone, with the lowest mass detectable at habitable zone orbital distances being 4 Earth-mass super-Earths.

So far, 4,000 planets have been detected outside the solar system and none have been shown to host life. But we have not looked that hard since there are at least 100 billion stars in the Milky Way galaxy and even more planets, so we still have a lot more to explore.

1.16 CAVITY REACTOR EXPERIMENT, CRCE

Built in the 1970s, CRCE was an outgrowth of a program begun by NASA in the 1960s to investigate the propulsion of space rockets by nuclear power, offering the possibility of much greater thrust per pound of propellant than chemical rockets.

The concept for the cavity reactor core was that the uranium would be in a vapor, or gaseous, state. Hydrogen as a propellant flowing around it would theoretically attain much higher temperatures of up to 10,000° F than in conventional solid core rockets. The experiments used simulated hydrogen propellant and produced data on the reactor physics feasibility of a gaseous core being able to go critical.

The core was uranium hexafluoride (UF₆); the experiments were all done at the relatively low temperature of about 200 °F.

In the proposed ultimate application, the ball of uranium gas would be held in place by the hydrogen flowing around it, something like a ping-pong ball suspended in a stream of air. Uranium core temperatures as high as 100,000° F were considered possible.

1.17 DEVELOPMENTS IN PLASMA, PHOTONIC AND LASER PROPULSION

Magneto Plasma Dynamic (MPD) thrusters were developed using a 250-kJ capacitor bank and pulse-forming networks at the NASA Glenn Laboratory. A high power steady vacuum facility is readied for for long duration MPD thruster tests at power levels up to 1.5 MW.

Ion acceleration and heating methods for advanced plasma propulsion were pursued at Princeton's Electric propulsion and Plasma Dynamics Laboratory. A coherent ion acceleration mechanism depending upon the nonlinear interaction of a magnetized ion with multiple electrostatic waves was researched; at least two of which differ in frequency by an integer multiple of the cyclotron frequency. The ions need not be in resonance and be coherently accelerated with an arbitrary low initial energy.

Magnetic field expansion for mini magnetospheric plasma propulsion was pursued at the University of Washington and NASA-Marshall research center. This concept generates a magnetically confined plasma bubble that achieves thrust through interaction by interaction with flowing charged particles in the solar wind.

Energy Sciences Laboratories (ESLI) constructed a microtruss fabric, from carbon fibers and whiskers. This thick porous material has applications in solar photonic sails. Areal densities of 1-10 gm/m² were achieved, with demonstration of the elastic self deployment of these structures after stowage.

Microwaves and lasers were used to impart momentum to small carbon sails at the Jet propulsion Laboratory (JPL). The sails were accelerated at several gs up to a height of 2 ft with a 10 kW microwave beam.

Laser experiments at Wright Patterson Air Force Base (WPAFB) demonstrated horizontal deflection of a pendulum-mounted sail with laser power ranging from 7.9 kW to 13.9 kW.

At the White Sands Missile Range, a thrust stand was used to perform static thrust measurements of Lightcraft models at different distances up to 120 ft from a 10 kW laser source. Laser to air energy coupling is being studied to increase the launches to several thousand feet.

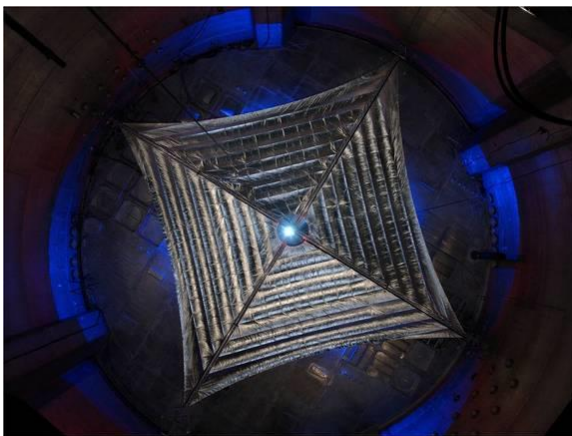

Figure 52. Sun-jammer solar space sail design for interplanetary travel. Source: NASA.

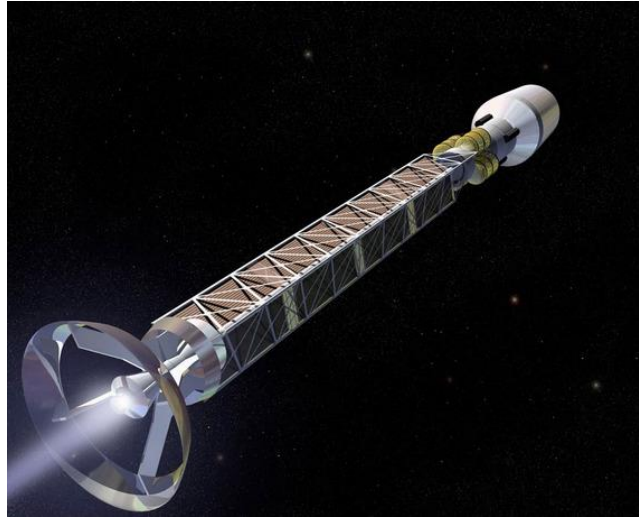

Figure 53. Conceptual design of an antimatter rocket engine.

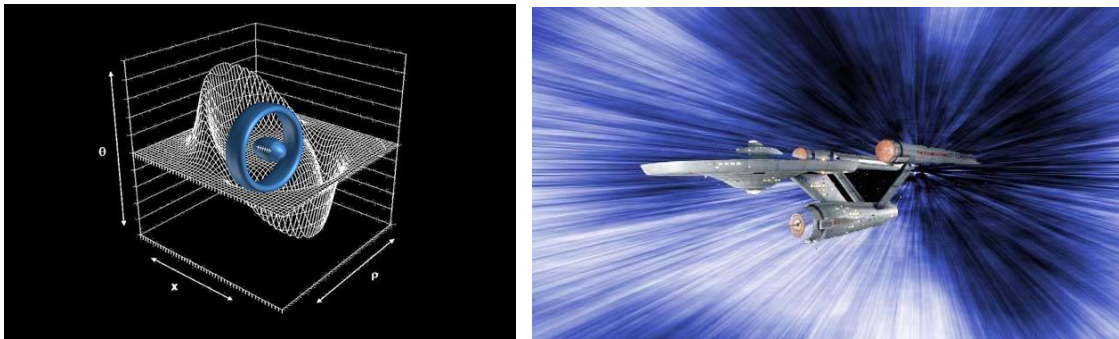

Figure 54. Futuristic Space-time continuum warp drive engine. Source: NASA.

1.18 DISCUSSION

Robert Frost, the poet wrote: “Some say the world will end in fire, others say in ice.”

The unique event of life on Earth will not last eternally. Biological life on Earth depends on the sun which will not last forever. The solar constant is gradually increasing, with the sun becoming brighter and hotter and larger. As the temperature of the Earth reaches 140 degrees F, the Earth will start losing its water supply. The atmosphere will be 10 to 20 percent water vapor rising to the stratosphere. There, water would break down chemically into oxygen and hydrogen. The hydrogen will escape into outer space. The oceans could disappear in about 1.2 billion years, turning the Earth into a lunar landscape.

Even sooner, warmer temperatures will cause the oceans to absorb a higher concentration of carbon dioxide, which is essential for plant life. In about 500 million years, plant life would

disappear as well as all life forms depending on plants. If the life of the Earth has been 4.6 billion years so far, with a 1/2 billion years left, the Earth is indeed in its old age.

As the sun exhausts its nuclear fuel and expands outwards in about 3.5 billion years, it will engulf with hot gases Mercury, Venus and the Earth.

Instead of fire, Earth could suffer from ice. If the gravity of a passing star disrupts the orbit of Jupiter, this could disrupt the Earth's orbit sending it into the cold of deep space.

We can modestly suggest, for life's future's perspective, that human knowledge about nuclear, plasma and radiation phenomena is necessary for our destiny as humans to help the living universe getting borne. Space exploration and eventually travel and colonization within and beyond the reaches of our solar system will depend on radioisotopes, nuclear and plasma energy, solar sails and even anti matter and space-time modification means for propulsion and survival. Note that there is no solar radiation to depend on at the far reaches of the solar system and beyond it.

Humans are bound to biologically engineer new forms of life adapted to the vacuum of space or on the surface of frozen moons, comets and asteroids. Such mobile life will free itself from the planets' gravitational traps inhibiting its free movement.

As Freeman Dyson suggests: "Perhaps our destiny is to be the midwives to help the living universe to be born. Once life escapes from this little planet, there'll be no stopping it."

REFERENCES

1. Gary L. Bennett, "Nuclear Technology on Mars," Book Review, Nuclear News, October 2000.
2. Gregory Benford, "The Martian Race," Warner Books, 1999.
3. George Schmidt, "Nuclear and Future Flight Propulsion," Aerospace America, December 2000.
4. Concetta G. Capoen, "United States Aerospace Nuclear Power Programs, A Compendium," U. S. Atomic Energy Commission, 1961.
5. J. S. Levine, "Terraforming Earth and Mars," in: Mars: Past, Present and Future, E. B. Pritchard, Ed., Progress in Astronautics and Aeronautics, Vol. 145, 1992.
6. D. A. Poston, "The Heatpipe-Operated Mars Exploration Reactor (HOMER), CP552, Space Technology and Applications International Forum-2001, M. S. El-Genk, Ed., American Institute of Physics, 2001.
7. J. S. Clark, "Nuclear Propulsion Technology Development: A Joint NASA/Department of Energy Project," "Mars: Past, Present, and Future," E B Pritchard, Ed., Progress in Astronautics and Aeronautics, A R. Seebass, Ed., Vol. 145, 225-237,1992.
8. G. P. Sutton, "Rocket Propulsion Elements, An Introduction to the Engineering of Rockets," John Wiley and Sons, 1986.
9. E. M. Goodger, "Principles of Spaceflight Propulsion," International Series of Monographs in Aeronautics and Astronautics, Division III. Propulsion Systems Including Fuels, Vol. 6, Pergamon Press, 1970.
10. J. A. Bonometti, P. J. Morton and G. R. Schmidt, "External pulsed Plasma Propulsion and its Potential for the Near Future," CP504, Space Technology and Applications International Forum-2000, M. S. El-Genk, Ed., American Institute of Physics, p. 1236, 2000.
11. George Dyson, "Project Orion, the True Story of the Atomic Spaceship," Henry Holt and Company, New York, 2002.

12. Ian O'Neill, "Alpha Centauri BB: An Interstellar Target?" Discovery News, October 18, 2012.
13. Tony Hoffman, "Alpha Centauri and the Dream of Interstellar Flight," PC Magazine, October 18, 2012.
14. Dan Vergano, "Glowing Reviews on 'Arseniclife' spurred NASA's Embrace," USA Today, February 2, 2013.
15. Mike Wall, "SpaceX Elon Musk Unveils Interplanetary Spaceship to Colonize Mars," http://www.space.com/34210-elon-musk-unveils-spacex-mars-colony-ship.html#?utm_source=syn&utm_medium=syn&utm_campaign=syn&cmpid=syn_spc_accu_weather, September 27, 2016.